

Learning from Incidents: How a Serious Fire in a High Pressure Polyethylene Plant Led to Improvements in Process Safety

Peter Shields, MSc, FSaRS, Safety Health and Environment Director, Innospec Inc, Innospec Manufacturing Park, Oil Sites Road, Cheshire, CH65 4EY

Innospec operates a high pressure polymerisation plant at Leuna in Germany. The main heart of the process involves ethylene together with catalysts, at pressures of over 2,000bar. In February 2014, the plant suffered a significant loss of containment followed by a jet fire. While there were no injuries there was considerable damage and disruption to the plant. The incident together with the outcome of the investigation is described as are the lessons learnt. The main ones being vivid reminders

Not to assume, even with older processes that all the hazards have been identified and appropriate controls put in place.

The need for appropriate specification and assurance measures for the maintenance of critical equipment even when employing specialist maintenance contractors

A summary of the actions taken as a result of this high potential incident is also provided. These relate to actions specific to the incident and of the wider implications for Leuna and Innospec operations.

Introduction

This paper attempts to illustrate what we have learnt as a result of a very serious incident at one of our manufacturing plants. It is not in any way a blueprint for how to get it right but may prove a useful insight into;

- a) What can go wrong especially for older plants if it is assumed that all the hazards have been identified by previous risk assessments.
- b) The need for appropriate specification and assurance measures for the maintenance of critical equipment even when employing specialist maintenance contractors.

About Innospec

Innospec is a global specialty chemical company serving a range of industries across the world bringing our products to customers in markets from oilfields, fuels, refineries, and power stations to personal care. Our team of approximately 1,300 employees spanning 20 countries with manufacturing sites in USA, Germany, France and the UK, delivers a turnover of more than \$1billion.

Our corporate process safety standards for Risk Assessment, Safe Operation, Management of Change, Safe Maintenance, Accident/Incident/Near Miss Reporting & Investigation, Emergency Response, Selection/Training and Competency follow industry best practice and form a core part of our sites SHE management systems.

About Leuna

Our operation, located in Leuna, Germany, is a relatively small facility located within a large complex chemical park used by many other companies. The Innospec operation consists of a high-pressure polymerisation plant for the production of products based on ethylene namely EVA, PE-waxes and diesel additives. The former state run company was privatised in 1997 and acquired by Innospec in 2004. 95 people are employed

Process Description

The high pressure polymerisation plant follows the process utilised by many other but perhaps larger operations around the world. Feedstock ethylene is compressed, in our case firstly to 250bar and then secondly to over 2,000bar. It is then fed into a 700 metre serpentine reactor together with various initiators to enable polymerisation to take place. The output from the reactor, after depressurisation, feeds either a wax handling process unit or a liquid blending unit depending on the product being made.

As the polymerisation reaction can undergo an uncontrollable decomposition reaction, the plant is continuously monitored by an array of temperature and pressure sensors. Any deviation outside the safe operational envelope triggers an emergency venting and shutdown operation. Production is controlled by a DCS system however the plants emergency venting system is a hardwired operation. The system is equipped with 4 large hydraulically operated relief valves, each one capable of venting down the process safely which protects the plant from any decomposition over pressurisation. These vent to the relief tower B850B shown on the right hand side of figure 1.

The plant also has several smaller pressure relief valves to protect the plant from pressure generated by any material trapped between closed valves when sections of the plant are isolated. These smaller relief valves have a dual operating mode with an electro-magnetic actuator and a spring mechanism. The electro-magnetic actuator would be activated (2,450 bar) by pressure monitoring system, if this failed and the pressure continued to rise the spring mechanism would be forced open (2,500bar). These smaller relief valves vent to atmosphere to the relief tower B850A shown in the centre of figure 1.

The reactor area does have gas detectors monitoring for gas leaks.

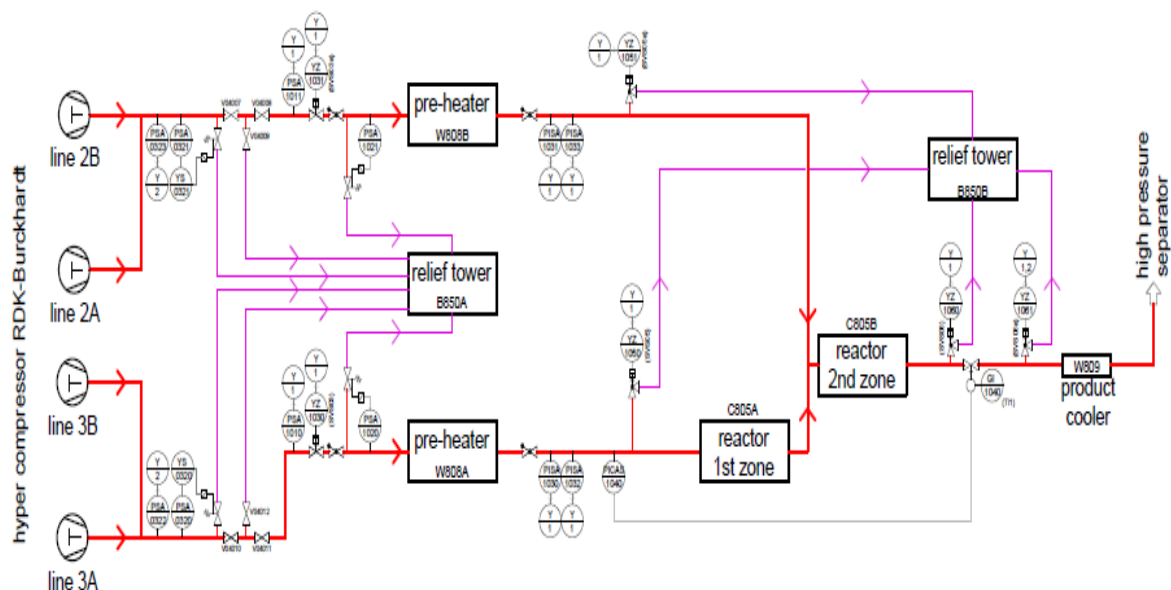

Figure 1 Outline Process Flow Diagram

Incident Detail

At 00:25 on the 21st February 2014 the plant was running without any apparent issue when a loud bang was heard and on investigation, fire was detected within the ground floor of the reactor chamber. Jet flames were observed, the plant was shut down and the site fire brigade called. The fire was extinguished within 20 minutes of the emergency call. Nobody was injured and although the damage was extensive no major structural damage resulted.

Initial Observations

The plant management found that the flame had emanated from a tell-tale vent on one of the thermal expansion valves located on the ground floor of the reactor area. In addition the electro-magnetic actuator of this valve had been displaced and the electrical connections broken. The flame damage indicated that some structural steelwork had been exposed to a high temperature typical of a jet flame. Electrical equipment on peripheral equipment had been damaged to a height of 3 floors above the ground floor.



Picture 1: Relief valve missing the actuator and showing the short stub of the tell-tale vent point



Picture 2: Structural steel work showing effects of extreme heat after exposure to the jet flame

Investigation Findings

The valve was reassembled and under test was found to pass at 25bar as opposed to its 2,500bar setting. In addition the vent line to the roof was blocked with polymeric material.

Dismantling of the valve revealed several issues some of which may have contributed to the incident others not.

- a) The connecting drive shaft from the actuator to the valve was found to be bent.
- b) Several albeit minor alterations to the valve internals were found
- c) Damaged bolting elements had been reused following a recent refurbishment
- d) Equipment with evidence of corrosion had been reused following a recent refurbishment.

Examination of the DCS logs showed that around 2 hours before the event the relief valve received a brief signal from the pressure monitor to open. This signal lasted for 1 second and then stopped. The alarm raised as a result was accepted and no further action was taken as such transient events had apparently occurred before.

From the same time the back pressure control valve on the main process stream made a series of slight closing adjustments up until the plant incident occurred.

The gas detection system monitoring the reactor chamber did not detect the presence of a flammable atmosphere.

Conclusions

Although we were not able to discover beyond doubt the detailed sequence of events the following scenario is most likely.

At around 21:57 when the valve received the brief 1 second signal it began to open, on the withdrawal of the signal it attempted to close but did not form a complete seal thus giving rise to a continuous leak. With the vent line blocked the pressure forced the gas into the body of the valve and out through the local tell-tale vent.

With no other process abnormalities this would appear to indicate that the expansion relief valve started to pass at this time and the back pressure control valve was able to compensate for the slight loss in pressure.

At 00:24 vibration or pressure caused the actuator to be forcibly displaced and the resulting rupture of the live electrical cable provided a spark which ignited the leak.

The ignition resulted in two jet flames, one at right angles to the valve via the tell-tale vent and the other directly in line with the valve via the actuator drive shaft.

Clearly there are a number of contributing factors to this event such as

- a) Why did the system call for the valve to open
- b) Why was the vent blocked
- c) Why did the valve not reseal
- d) Why did the gas detectors not detect the presence of a flammable atmosphere.

Why did the system call for the valve to open

The independent DCS system did not register any pressure excursion. The hard wired pressure gauge, due to fire damage, could not be fully tested but it is presumed that a brief spurious signal occurred. This was apparently not an unusual event as

confirmed by the operator accepting the alarm and taking no further action. In this process there is an inherent vibration issue throughout the plant due to the types of compressors that have to be used. For this reason the pressure gauges are oil filled to dampen the effect of vibrations in an attempt to prevent spurious alarms however it is evident that sometimes this dampening can be overcome.

Why was the vent blocked

The occasional brief opening of the relief valve or slight passing of the valve would allow polymeric material to pass into the vent system which then subsequently built up to form a blockage.

As a result of this finding all other similar vents routes were examined and several others were found to contain similar blockages.

Why did the valve not reseal

The spindle driving the valve seat became bent either before or as a result of the action at the time which prevented it from resealing. These valves are of a special design suitable for very high pressure duty. As such their maintenance and testing is beyond the capabilities of the in-house team. A maintenance contractor with experience of high pressure systems was employed to provide this service. The investigation revealed that other than a general request for the testing and refurbishment there was very little provided to or asked for by, the contractor on the specification of the tasks required. While it cannot be categorically stated that the poor standard of refurbishment was the direct cause there is no doubt that there was sufficient play on the spindle to allow it to leave its normal central position thus allowing the potential for deformation during operation.

As a result of this finding all of the other, in service and spare (refurbished) expansion relief valves were subject to a detailed examination. Several of these exhibited similar evidence of a poor standard of refurbishment although all had passed the standard test procedure before being handed back.

Why did the gas detectors fail to pick up the leak

The point source gas detectors were located in the main reactor area away from the location of the relief valves.

Immediate Cause

The relief valve, when it failed to reseal, vented into a blocked vent system and found a least path of resistance through the valve body and the tell-tale vent, into the local area. After a considerable passage of time the gases found an ignition source, probably a spark created when live electrical cable snapped.

Basic Cause

The original and subsequent risk assessments for the plant failed to identify the risk of blockages should the relief valves pass or receive spurious signals, as a result

- a) There was no perception that a major leak into the local area could result if a valve passed.
- b) The tell-tales vented local and not to a safe place.
- c) The distribution of the gas detector system was focused around the main area of the reactor and not in the vicinity of the tell-tale vent of the relief valves.
- d) There was no means of detecting if the valves were passing
- e) There was no routine inspection of the vent lines
- f) While there was a preventative maintenance schedule for the relief valves there was no formal detailed specifications/instructions given to the contractor.

The Leuna plant was built over 60 years ago and while a DCS control system has been introduced no other significant physical changes have been made to the process. In particular the expansion relief systems were part of the original design of the plant. Since taking over ownership of the plant the risk assessments have been carried out but did not question the original equipment design which had previously not given any cause for concern.

Actions Taken

The actions taken included

- a) Actions specific to the incident
- b) Actions related to the wider implications for Leuna and the company

Actions Specific to the Incident

1. Relief Valves Systems

A re-evaluation of the need for the expansion relief valves was carried out with the assistance of an external specialist. It was concluded that the plant could be modified so that the prospect of locking in material between valves was no longer possible. After conducting a HAZOP all the isolating valves in the process stream were removed thus allowing the removal of the expansion relief systems, see figure 2.

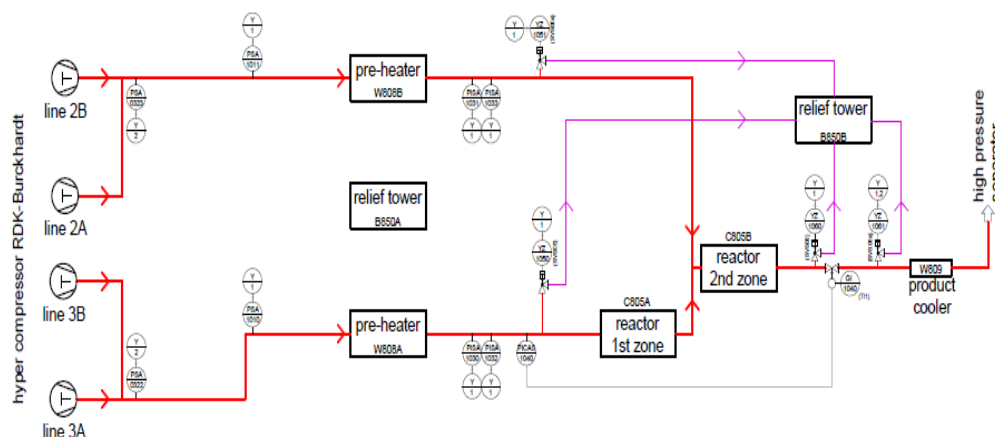

Figure 2: Simplified Process

2. Gas Detection

Although the relief valves and their associated tell-tale vents have been removed the gas detection system has been extended to cover a wider area within the whole reactor chamber. In addition a CCTV system has been installed to enable operators to observe the reactor chamber which is an area of the plant that cannot be entered when the plant is running.

Wider Implications

a) Leuna

The management team have recognised that several aspects of the incident indicated wider implications that should be addressed;

1. The design of the plant is in the process of being reviewed on a prioritised basis and options for simplification examined. This includes the choice of process equipment and process control systems. Where options are identified then before any changes are made a HAZOP is carried out chaired by an qualified independent chairman.
2. The use of a specialist maintenance contractor does not remove the need for assurance that the service expected is the service received. Nothing should be assumed; clear written specifications should be drawn up and agreed with the chosen specialist. Such written instructions have now been created for all work on critical equipment that is carried by external contractors. Checks against these specifications are carried out as the equipment is returned.
3. Likewise it cannot be assumed that in-house activities require any lesser specification. The same level of detail is required and has been created, for maintenance activities carried out by the in-house maintenance team. In this respect the re-fitting of equipment has come under particular scrutiny i.e. flange connections of which there are many thousands. There is a programme of work to ensure that flanges carry a specific means of identification, that specifications have been drawn up for the materials to be used, that the torque settings to be used and records kept so a history of each valve can be drawn up over time. Checks are made by an independent person as assurance that joints are being correctly made.
4. A preventative maintenance schedule has been created for all remaining vent lines to be examined for blockages. This has initially been set at three monthly intervals which can be altered in the light of experience.
5. A system is being designed to monitor the vents systems for flammables to enable early detection of any passing valves.
6. Re-training of the management team in hazard awareness in particular for fire and explosions has been put in place.

b) Company

The company has recognised that the experience at Leuna has wider implications for the whole group and has created a manufacturing best practice group to share amongst other things how the quality of maintenance activities can be controlled. Examples include

1. A review by an independent specialist to assess the current maintenance management system. This has resulted in an on-going programme of work to further enhance sites maintenance quality.

2. Recognition that having experienced time served fitters does not mean that refresher training is unnecessary. Courses to remind fitters and their supervisors of the importance of flange specifications and the use of the correct torque settings have been established.
3. A companywide training scheme for hazards awareness has been created with 23 representatives from our European manufacturing sites attending the 1st session in March 2015. The course is to be repeated for our USA operations later in the year.
4. Sites have been reminded that any activation (real demand or false alarm) of a safety critical safety system should be reported and investigated as a process safety incident or near miss.

Closing Summary

The fire at Leuna was a salutary experience, one that reminded us that despite having developed Process Safety Standards this does not automatically mean that everything is as it should be. If the full range of hazards and how they can arise are not identified at the risk assessment stage then the correct controls may not be put in place. In addition if the equipment that is utilised within a high hazard plant is not subject to a quality maintenance regime including the formal specification of what is required and assurance that it has been performed, then at some point it will let you down.

All of this is easy to say and should be obvious but it is not always easy to implement or maintain without continued rigour and vigilance. As pointed out at the beginning of this paper describing our experience is not intended in anyway to be a blueprint for others to follow but it is hoped that it provides some thought provoking insights. We feel that the experience, by illuminating the level of detail and vigilance required, has helped us to strengthen our approach to process safety. We also recognise that this journey never stops.