

## Particles over a lifetime: The 2017 Kennedy-Wunsch lecture

John Abrahamson, Auckland, 16 May 2017

This presentation gave some background to my work over the years 1970 to the present, largely done while a teaching staff member in the Department of Chemical and Process Engineering, University of Canterbury, and then working for the spin-off company ArcActive in Christchurch over the last decade. The work largely was about particles of various sizes, and all of the work presented during this 2017 Kennedy-Wunsch talk concerned particles. Although I was trained as a chemical engineer, the field of application of the work covered many other disciplines such as chemistry, physics, botany, materials and fluids science and cosmology, and industrial applications such as dust collection.

The topics presented below have all been challenging areas in which to generate insight. They have been challenging also to my associates (students and other colleagues) and most importantly they have been fun to do, for everyone involved. Underlying all this work, has been my commitment to the practical philosophy of Sir Karl Popper<sup>1</sup> that encourages one always to challenge what one reads and hears, both ideas and reported measurements, to the best of one's ability, even if it represents the well received status quo opinion. This represents the only way to fully understand what others have published. If one can devise another way of explaining the measurements others have published (even if the new explanation is flawed!), one has burrowed deep into their work, sometimes deeper than the original authors have done. This approach has helped all my students, and some have taken to reading the formal parts of Popper's philosophy itself. The easiest way into a challenging area is to focus on any apparent conflicts in published data or mechanism. Conflicts usually mean that something has been left out of consideration. An important part of this effort is to try to clearly visualise the physical system and what it does. Often the visual answer to the conflict comes from one's subconscious some time after doing the donkey work on the published papers, when one has relaxed away from the minutiae of the problem.

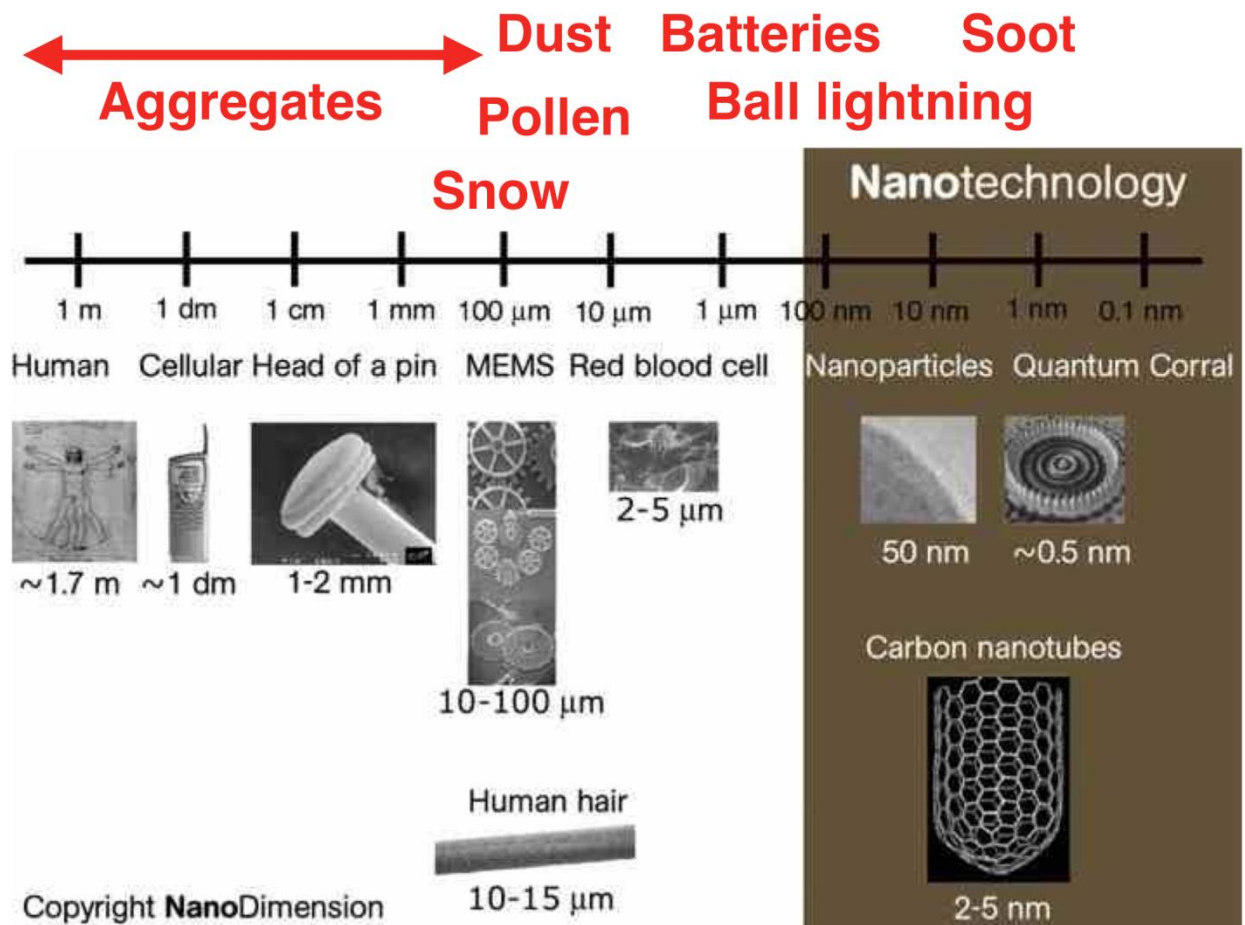

"Particles" in this talk

**Carbon nanotubes**

The topics covered in this talk are given above in red labels, placed on a chart of particle size, from molecular to the size of a man. The names of my major collaborators are listed under each heading.

# Carbon nanotubes

1975 - 2010

With Peter Wiles & Clive Davies

There is a general acceptance that the 1990's onward is the "nano-age", with a focus on the science and technology of objects a little larger than molecules, and considerably smaller than the wavelength of light or the diameter of a human hair. This range is from about 1 nm up to several 100 nm, and includes modern electronic elements etc. The slide below recounts how the fascination with things "nano" came about.

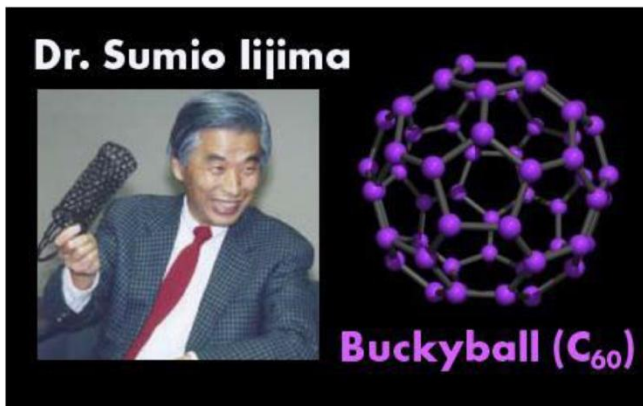

## Arc-Discharge Synthesis

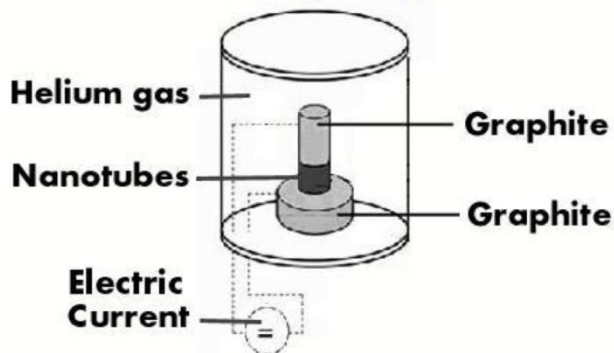

## How did it start?

- 1984 C<sub>60</sub> "buckyball" discovered in US
- 1991 Japan, Carbon nanotubes discovered
- Interest spread into traditional areas
- 1978 Canterbury found nanotubes

## History: The start of the "nano-revolution"

4

The discovery of the 60-atom carbon ball ("Buckyball" or "Fullerene" after Buckminster Fuller, the American architect who was fond of large geodesic structures) started the widespread interest. This was followed by the single-walled carbon nanotube (SWNT) found by Iijima in 1991. At Canterbury, we found multi-walled carbon nanotubes (MWNT) well before this, in 1978, although we called them "fine carbon fibres" or colloquially "carbon grass". There was little reaction when we published our accounts of the finding, even though we sent samples to 5 well-known laboratories around the world.

# Electric arcs at Canterbury, 1970-80

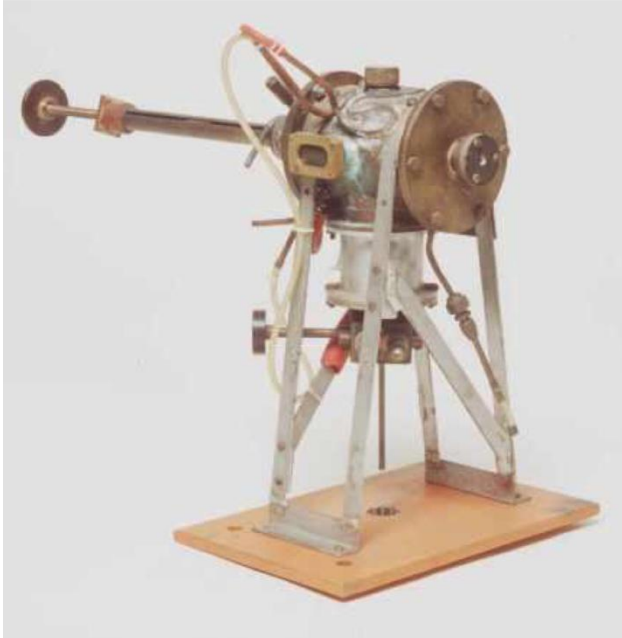

View of arc, 10-15 A in nitrogen

“standard arc” apparatus in which JA and Peter Wiles found nanotubes

The above shows the batch-wise apparatus in which we found MWNT, and a side view of the arc struck between two carbon or graphite rods or electrodes. We were experienced with electric arcs as our major project was to continue developing an electric arc reactor to manufacture acetylene gas from carbon made from NZ coal. This was started by me in my PhD work, finished in 1971. As part of this industrial project, we wanted to standardise our optical method of measuring the temperature of our electrodes. We knew that the best way of doing this was to build a "standard arc" where the arc was carefully controlled at low currents and provided a smoothly running arc. Viewing the positive electrode with a pyrometer gave a blackbody temperature of 3800 K with a variation of only 5 K!

Slide 6 shows the geometry of the arc (in orange) between the black electrodes. The anode (or positive) electrode is viewed perpendicular to its large end.

Abrahamson & Wiles (1978)

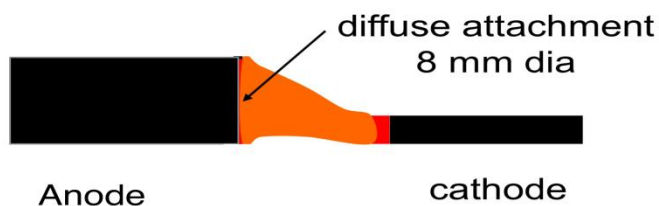

Carbon arc in quiet operation (15 A)  
For steady radiance source

This arc was conventionally run in air (at atmospheric pressure), but we decided to run it in nitrogen to slow down the erosion of the electrodes. To our surprise we saw some big differences in the fine structure on the electrodes after shutting the current down. We investigated the fine structure because we noticed rainbow colourings coming from the electrode face.

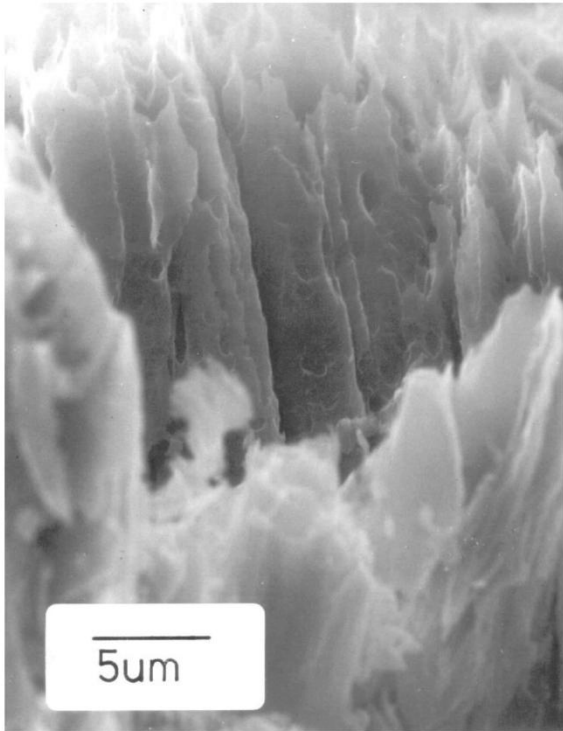

After air operation

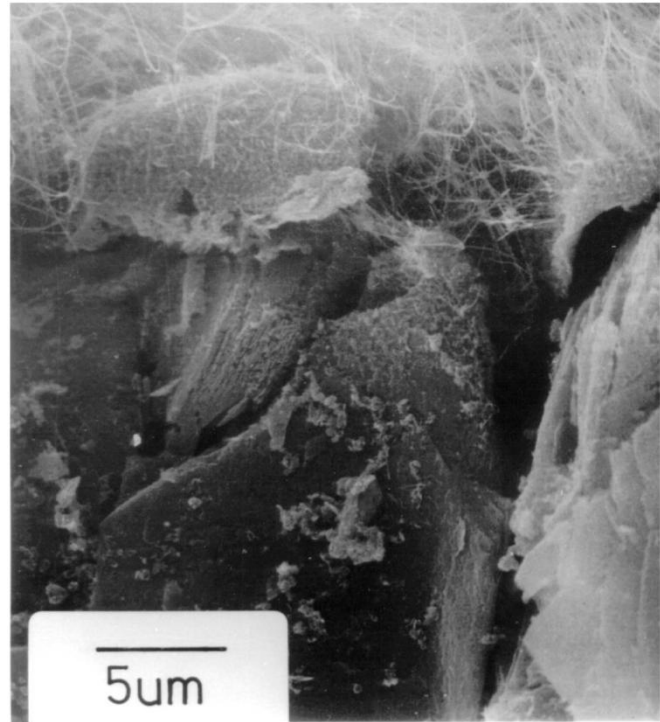

After operation in nitrogen

1977 carbon arc reactor - anode surface under SEM  
 "Carbon grass" now called universally "Carbon nanotubes"

The slide above shows fine fibrous growth on the end face after operation in nitrogen (the electrode was split down the middle and we examined the corner where the fracture (vertical in the photograph) met the end face of the electrode (horizontal)).

A small part of the sample shown in the slide was examined at higher magnification under the transmission electron microscope (TEM), and showed that the diameters of the smallest fibres was several nm.

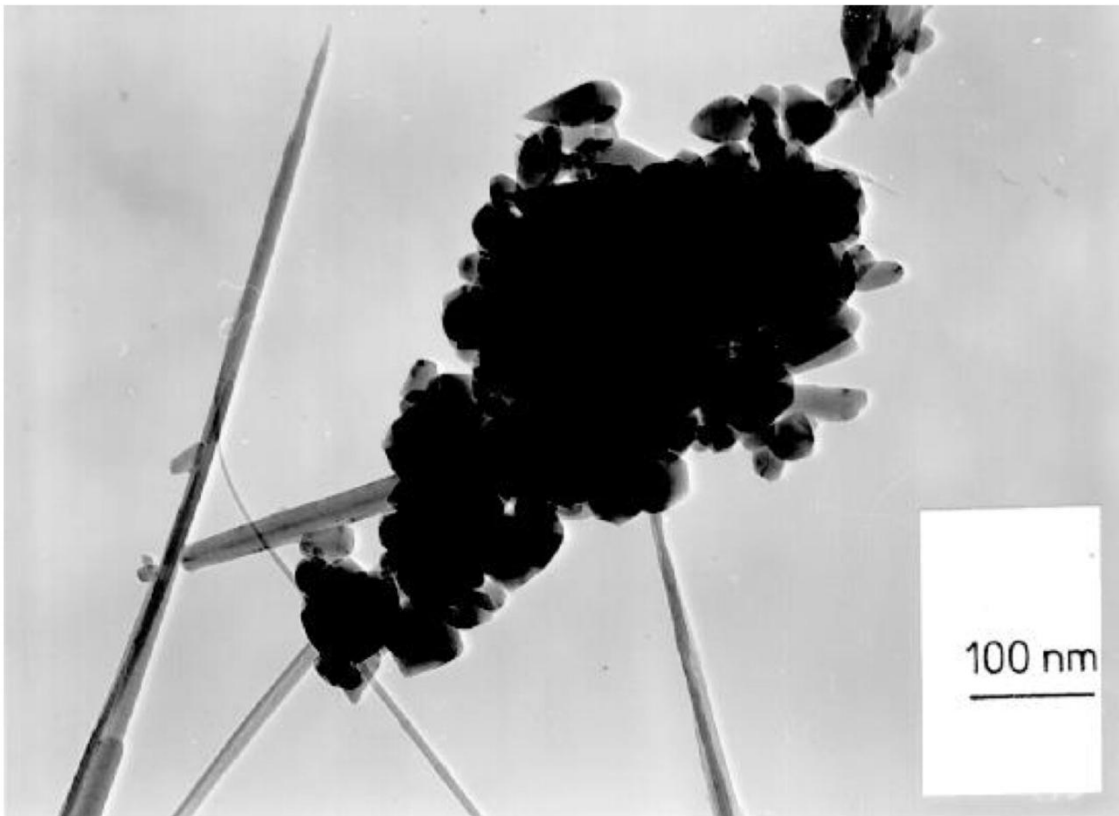

## Nanotubes holding crystallites

1977 TEM (transmission electron microscope)  
Nanotubes several nm in diameter, multi-walled

8

We (with help from Brian Rhodes of the Mechanical Engineering Department at the University of Canterbury and the Christchurch Public Hospital) also studied the electron diffraction patterns of the fine fibres, and concluded that the carbon fibres were made up of graphitic layers wrapped around to make a tube. This was presented to a carbon conference in the US in 1979.

- Nature article on who found the first multiwalled nanotube - writer Phillip Ball, 2001 concludes that Abrahamson & Wiles did this.

## Who saw the first nanotube?



The history of carbon nanotubes may be a little longer than was previously thought. Richard Smalley of Rice University in Houston, Texas, points out that nanotubes could have been unknowingly produced by late nineteenth century chemists experimenting on methane<sup>21</sup>. And in the 1960s and 1970s, at least two groups made and characterized the tubes, only for their discoveries to go largely unnoticed.

Roger Bacon of the National Carbon Company in Parma, Ohio, then part of Union Carbide, produced nanoscale scrolls of graphite in 1960 (ref. 22), confirming their dimensions and structure using microscopy and X-ray diffraction. Bacon's work may have been ignored by science historians, says Smalley, because of the view that he made scrolls. But recent work<sup>23</sup> has shown that Sumio Iijima at NEC in Tsukuba, Japan, who in 1991 published what is often thought to be the first paper on nanotubes, was using a procedure that generates a mixture of scrolls and tubes, suggesting that Bacon may also have done this.

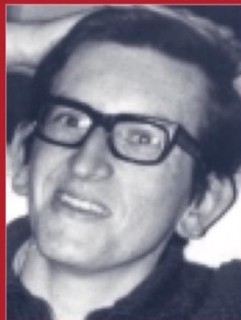

In the late 1970s, Peter Wiles (bottom, left) and John Abrahamson (top, left) of the University of Canterbury in Christchurch, New Zealand, went one step further. They were investigating the carbon fibres produced when sparks were passed between two graphite electrodes, and found that one of the electrodes was coated with "mats of small fibres"<sup>24</sup>. In 1979, electron-diffraction measurements showed that the walls of these 'fibres' were made of carbon in a graphite-like arrangement. They described the tubes as made of several layers of crystalline carbon "wrapped together" — they had discovered multiwalled carbon nanotubes.

**of several layers of crystalline carbon "wrapped together" — they had discovered multiwalled carbon nanotubes.**

The contrast with the excited reception of Iijima's paper is remarkable, and illustrates how new discoveries rely on the prevailing research climate. In an age before nanotechnology and the fullerene-induced interest in carbon chemistry, there seemed little reason to regard the fibres as anything more than a smaller version of familiar micrometre-scale carbon fibres. "Although we figured we had found something novel, we never for a moment imagined the eventual significance of the discovery," says Wiles.

Phillip Ball, a regular science writer for the journal "Nature", assessed the history of the discovery of carbon nanotubes around 20 years later, and concluded that we had indeed been first to the structure of multiwalled nanotubes.

We came back to the carbon arc study around 2000 at the prompting of one of the discoverers of the buckyball, (Robert Curl) who was visiting the University of Canterbury at the time. Our idea was to make the deposition of carbon nanotubes continuous onto a moving tape that formed the anode. The essence is shown in slide 10.

## Canterbury arc reactor with no anodic contraction

- 16 A, 1 atm
- deposit NT on *anode* (tape)
- Molecular diffusion dominated

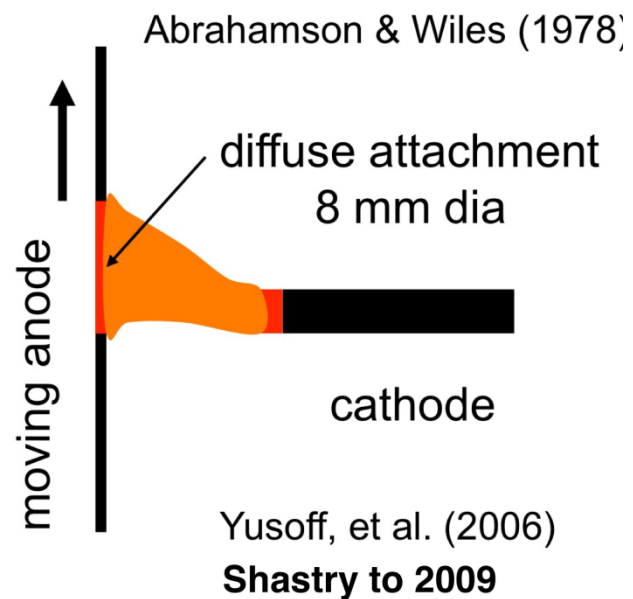

The 1978 arc was operated on a moving anode, (2000),  
making CNT *continuously*

10

The curious aspect of the arc was its milky colour. Our explanation for this was that fine carbon crystallites were suspended in the arc, and emitted radiation as a black body at its temperature. We were confident that the bulk graphite of the positive electrode was at around 3950 K corresponding to the sublimation temperature of bulk graphite. However the observed temperature looking at the positive electrode face was much lower at 3800 K. The idea we had was that the suspended particles were obscuring the hotter back surface, and cooler than the electrode face despite being immersed in a much hotter gas. They were cooled by their sublimation and were in equilibrium with the vapour around them, at their sublimation temperature which was lower than that of the bulk graphite because of their significant surface energy. This suspended material could also have been partly single layer material (graphene), as indicated in slide 12.

Canterbury arc reactor 16 A, electrode gap 5.2 mm

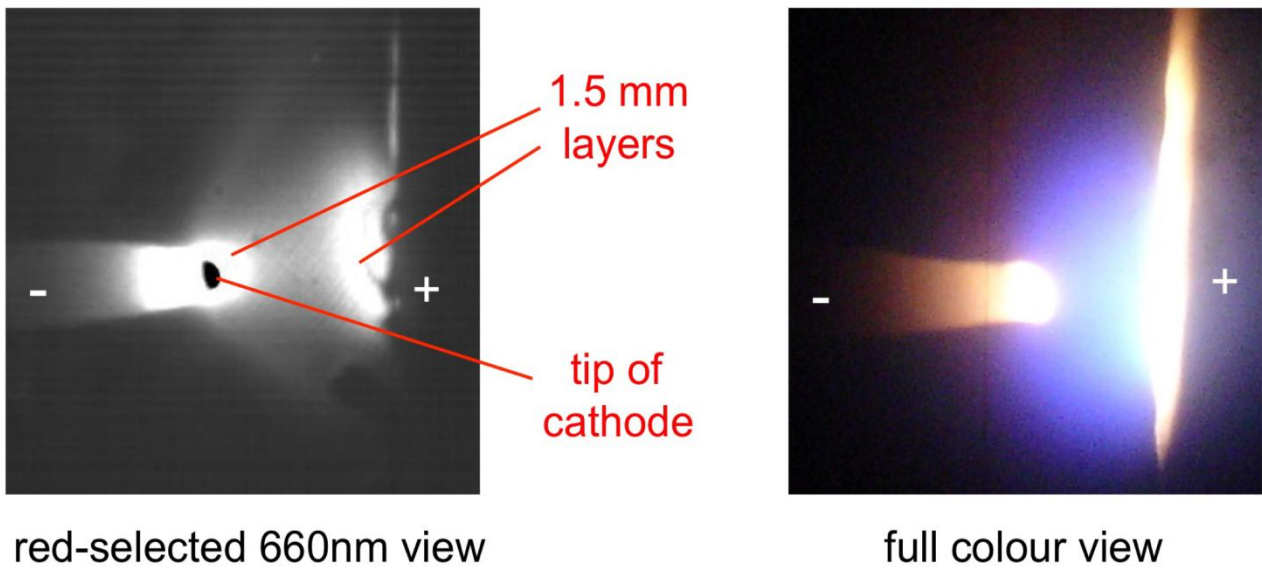

red-selected 660nm view

full colour view

slow-moving laminar arc

What is the source of the milky light in front of the anode?  
Have argued for graphite crystallites & graphene

11

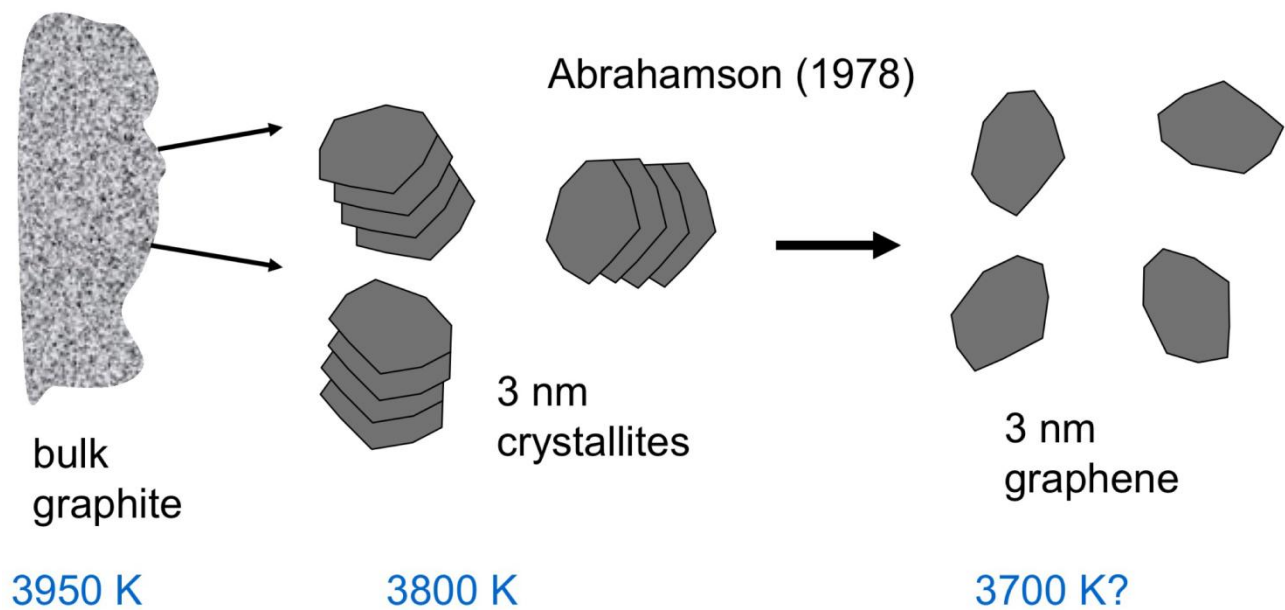

equilibrium sublimation temperature at 1 atmosphere

Surface energies of these small particles brings the observed *equilibrium* temperature **down**.



# Turbulent agglomeration

## 1975

This work was prompted by an interest in cyclone dust collectors that was started by some practical experience provided by the Christchurch based consulting chemical engineer Charles Martin. The high efficiency of collection of fine dust particles observed with some of the larger cyclones did not seem realistic if the particles were collected as single particles. If they were collected as aggregates the collection appeared more reasonable. The flow of gas in a cyclone is almost always turbulent. Thus the rate of collision of dust particles in a turbulent gas was of interest.

Two particles colliding:

*Saffman & Turner (1956)*  
approach:

**Both particles in same  
(shearing) eddy**

*Abrahamson (1975)*  
approach:

**Particles in different  
eddies**

*(Catapulting outside eddy  
into path of another particle)*

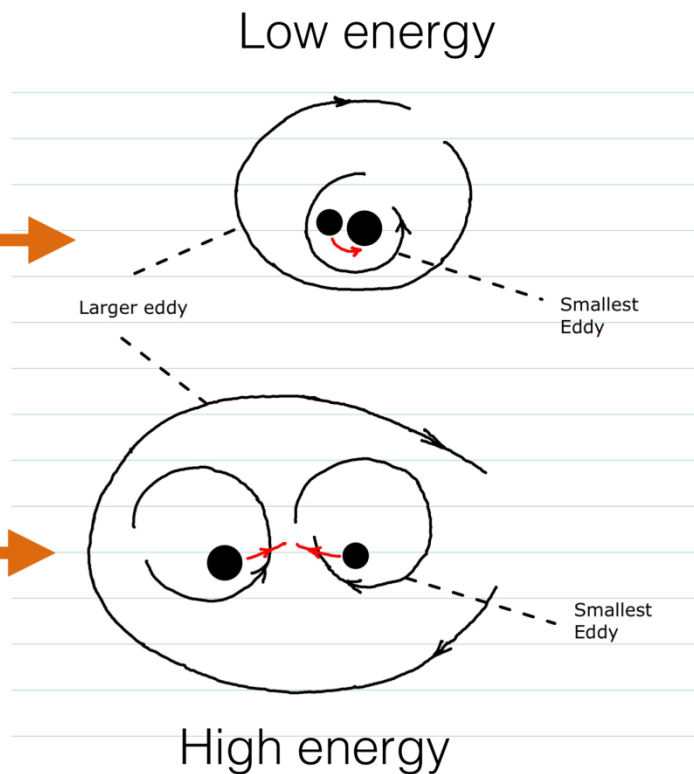

14

The rate of collision estimate provided by Saffman and Turner (1956) appeared to be valid only for low energy turbulence, lower than that expected in the high shear flows near the inner wall of a cyclone (see later in this talk). Thus an attempt was made to provide a high energy collision theory. This was done by a "slingshot model" where one particle was slung out of the eddy it was in, to impact on another particle close by but moving in another eddy. If the particles were originally further apart than the correlation distance of the turbulent fluid, then they had independent velocities. Then the collision rates of the molecules in an ideal gas could be taken from the classical gas theory, and applied to the particles. As they approach their collision, there is still a chance because of the fluid in between them that they move around and avoid each other. At high energies this becomes negligible.

The particle velocities are Normally distributed, like the fluid, but reduced somewhat. Their standard deviations were calculated from previous turbulent models, and the particle velocity expressed as a function of the fluid velocity, particle relaxation time and fluid energy dissipation rate per unit mass. The 1975 formulae have been used in many different fields.

*High energy turbulence:*

Long cascade of eddies large to small eddies

Random velocities equal in all directions

**Can use the traditional gas molecule collisions model**

With a particle fluctuating velocity  $U_p$

Related to fluid fluctuating velocity  $U$

$$\overline{U_p^2} = \frac{\overline{U^2}}{1 + 1.5\tau_p\epsilon/\overline{U^2}}$$

Particle  
relaxation time

Energy dissipation rate  
per unit mass

**Since 1975, 230 citations with steady rate to present**

15

## Soot formation

1977

This foray into how soot particles are made in pyrolysing hydrocarbons and flames, took as much effort as the aggregation theory. One whole year in Cambridge, UK was spent working through gas kinetics connected with acetylene as a first intermediate. It resulted in a paper published in *Nature*, and covered both radical and ionic intermediates.

## Soot clusters

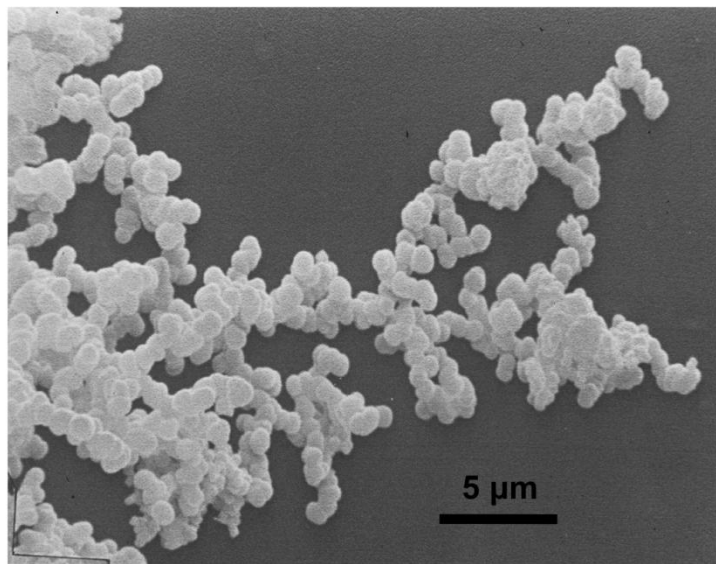

- usually single-centred balls
- aggregated by diffusion
- fractal  $d \approx 1.8$

Soot is composed of "onion-like" aromatic skins in sub-micron sized spheres that attach to each other in randomised chains.

The second intermediate in soot formation was proposed (1977) to be a "mattress" molecule with solely single C-C bonds, containing free radicals on its edges. This "saturated" structure has recently (mid 2000-2010) been recognised and labelled as "graphane". I did no experimental work on soot or pyrolysis since publishing, and probably because of that, have had little further interaction with those in the field.

## Saturated platelets

Abrahamson 1977

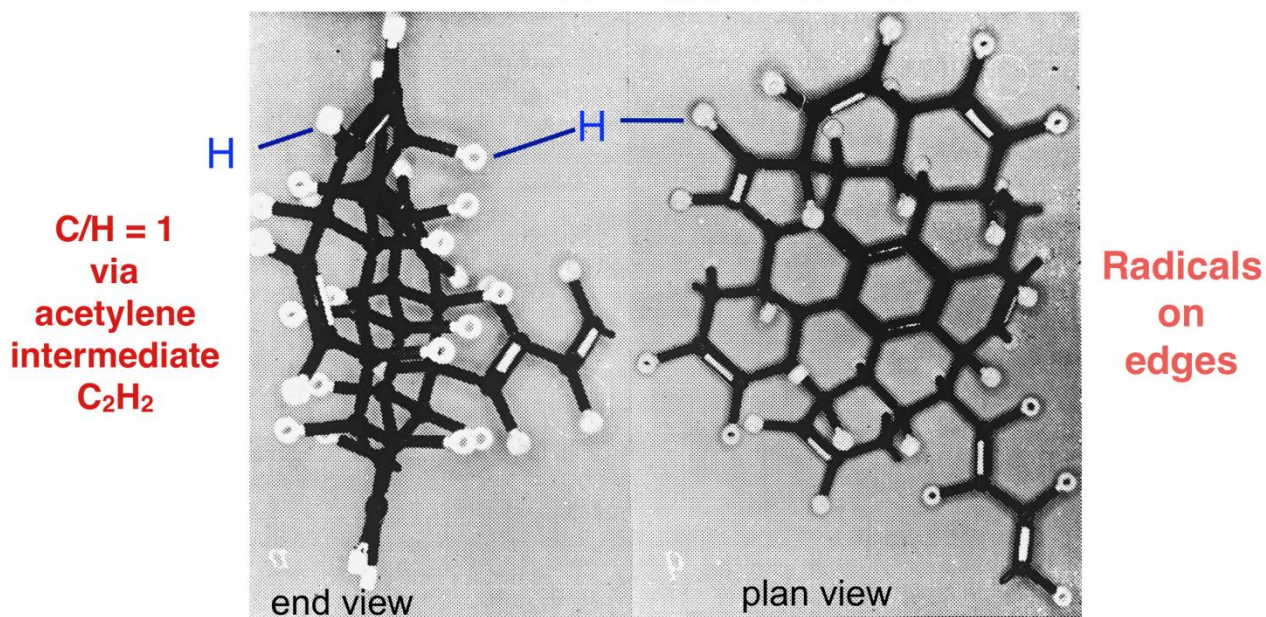

An intermediate in soot formation was proposed in *Nature* (has had 25 citations). Structure is now "graphane" (2007)

# Snow avalanches

1980 - 1985

With Howard Conway & Martin Bell

My research students dragged me into this area, particularly Howard Conway who worked as a mountain guide, and had lost friends in avalanches.

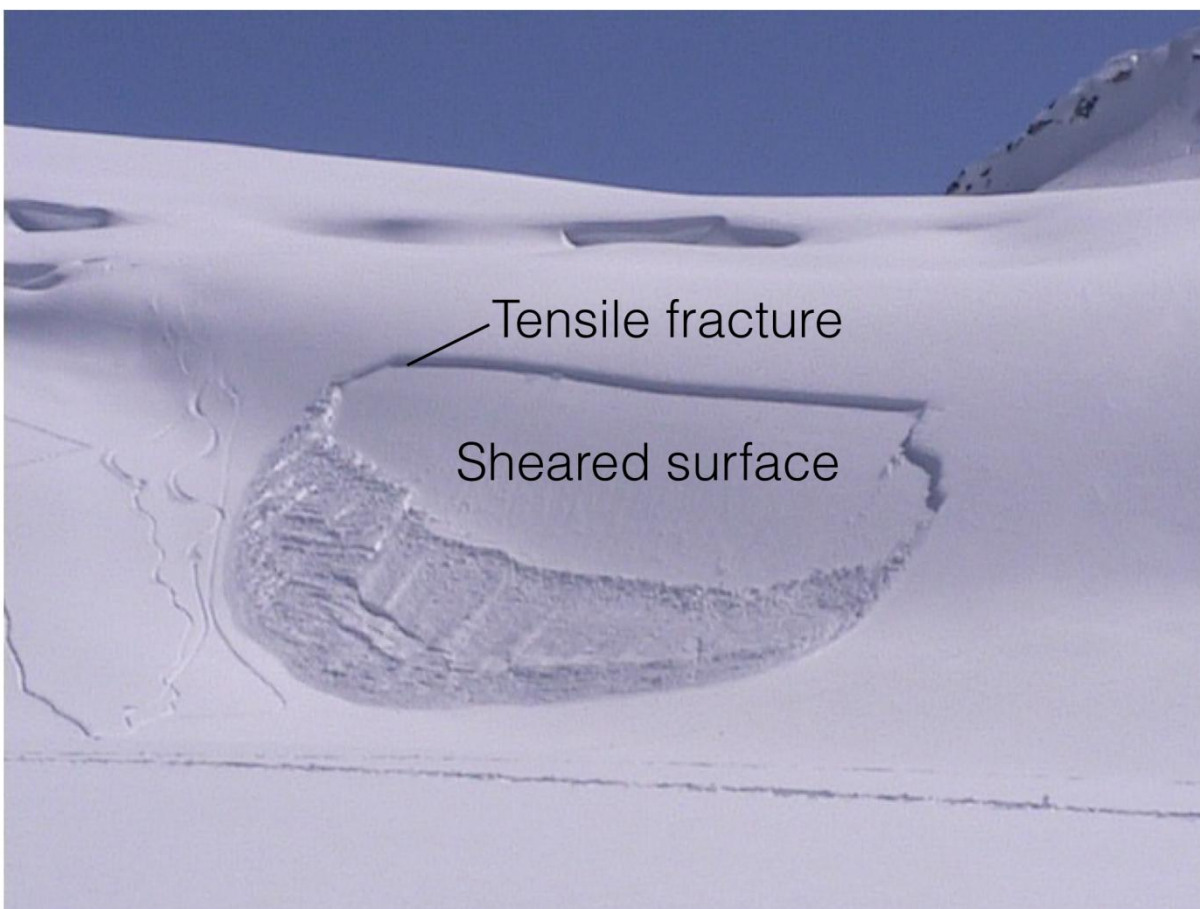

60 m wide 2 m deep slab avalanche (note ski trails on left, afterwards)  
Where did it start, and how?

This slab has failed both by shear across the basal plane and by tension across the top end. But the failure will not have been simultaneous in all areas. Note it was 60 m across. Where did it fail first?

In order to answer this question, measurements of shear strength and tensile strength of the snow slab had to be made, at various locations across the slab.

One often sees corrugations along the snow slab.



**Plate 3:** Surface snow waves on Hochstetter Dom Shoulder.

Length between waves around 2-3 m

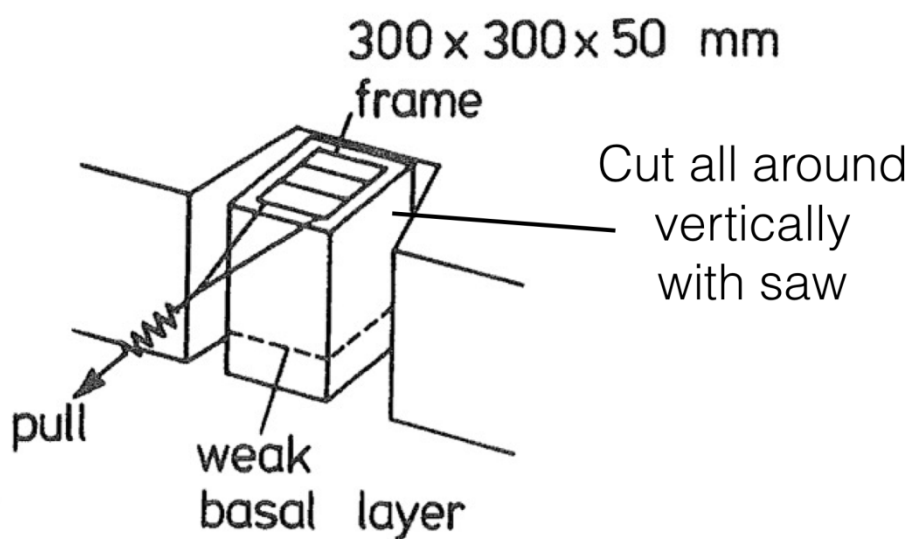

Measuring the shear strength of the snow slab along the weakest layer

Using a snow saw, blocks of snow were isolated from the slab, and pulled with increasing force until failure. A shearing stress was calculated, and the vertical position of the weakest layer noted.



Plate 5: Multiple pits across the Murchison Headwall to measure spatial characteristics of strength.

How much strength variation across the snow slope?

Either Howard or myself has been working steadily across the slope, cutting out pits and shearing them.

Shear strength has been plotted from measurements made every metre. The oscillations have a similar length scale to the visible corrugations.

We found there were many areas with almost no shear strength, and so the failure could have started from any of these. This was the first time a complete profile and this size of variation was published. We worked

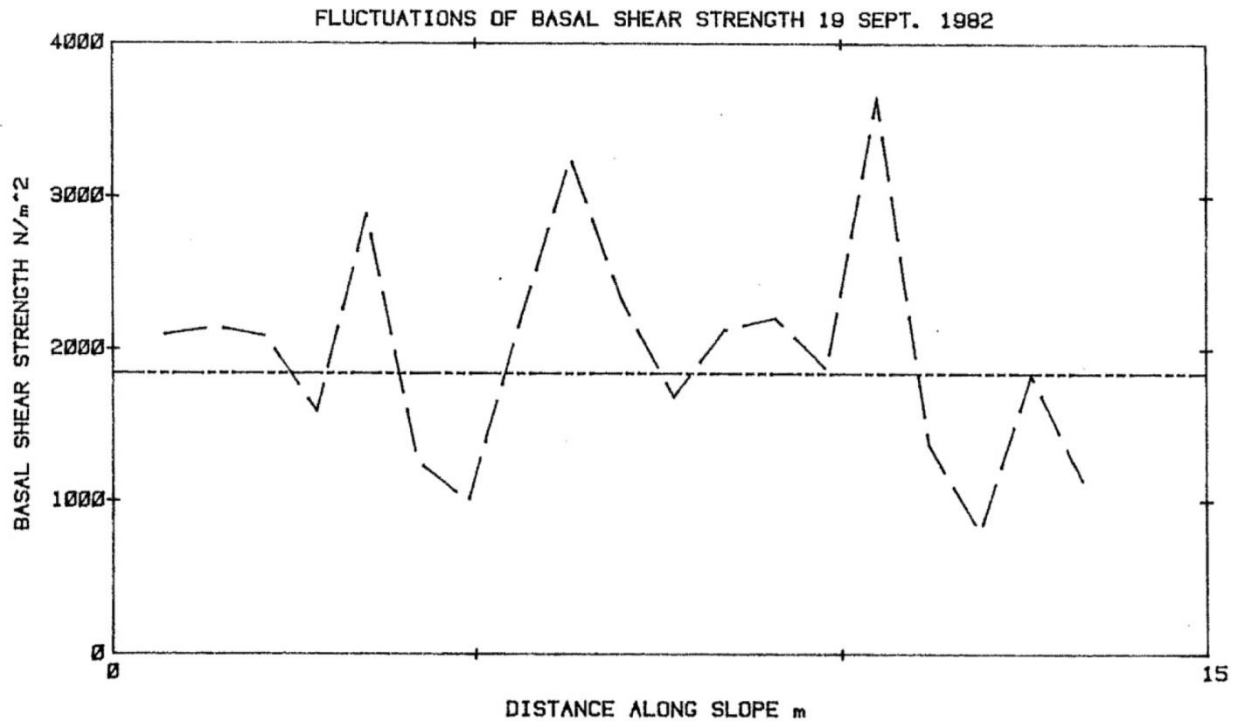

Figure 5.2

Similar profile of weaknesses to that seen of dunes  
(2 m)

up a probabilistic analysis for failure and published it, and an international effort along these lines continues to the present (29 citations).



We wanted to understand about the development of weaknesses and strengths in the snow. We realised that the large eddies (around 1 km transit distance) crossing over the snow field were causing correspondingly slow air pressure cycles, and also causing air to pump vertically into and out of the snow. In the presence of vertical temperature gradients, water vapour could move with the air and condense along the path.

Condensation will preferably be made around the joins between the snow particles, strengthening their bonding together. This explains the often-found hardening of snow during "hard blows".

## Wind effect on snow in slab

Measured air pressure at surface  
of snow  
Fluctuated 15 min cycles

Indicated 1 km sized air eddies  
passing over

Temperature profile  
through snow

Air pumping enhances water  
evaporation & condensation,  
**hardening snow**

Found this experimentally in lab.  
First realisation of this, have not  
published this!

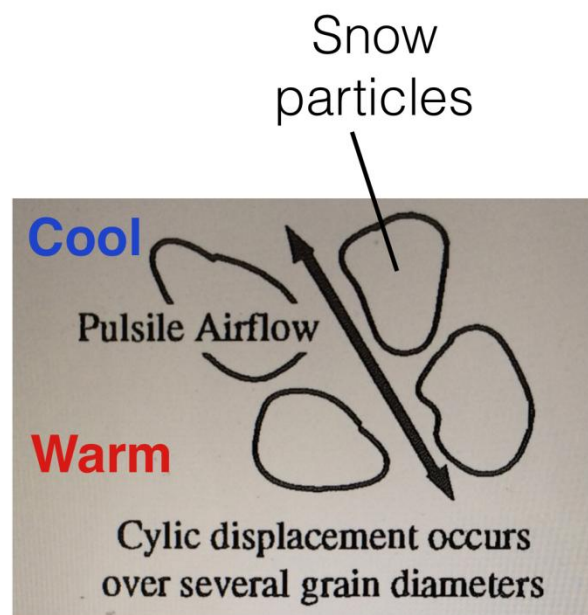

Now for some horticultural work, both in the orchard and the lab. Michael Hii excelled in both of these areas and in computer flow dynamics (CFD).

# Kiwifruit pollination

1985-1990  
With Michael Hii  
(Zespri support)

Orchardists are faced with some difficult issues when managing pollination of kiwifruit flowers.



Bees - No nectar in female flowers,  
Wind & bees - only 6 days pollination opportunity

1. Vines are either male or female, and the overlap of their flowering is only around 6 days.
2. Bees stop pollinating the female flowers after a few days because there is no nectar in the flowers.

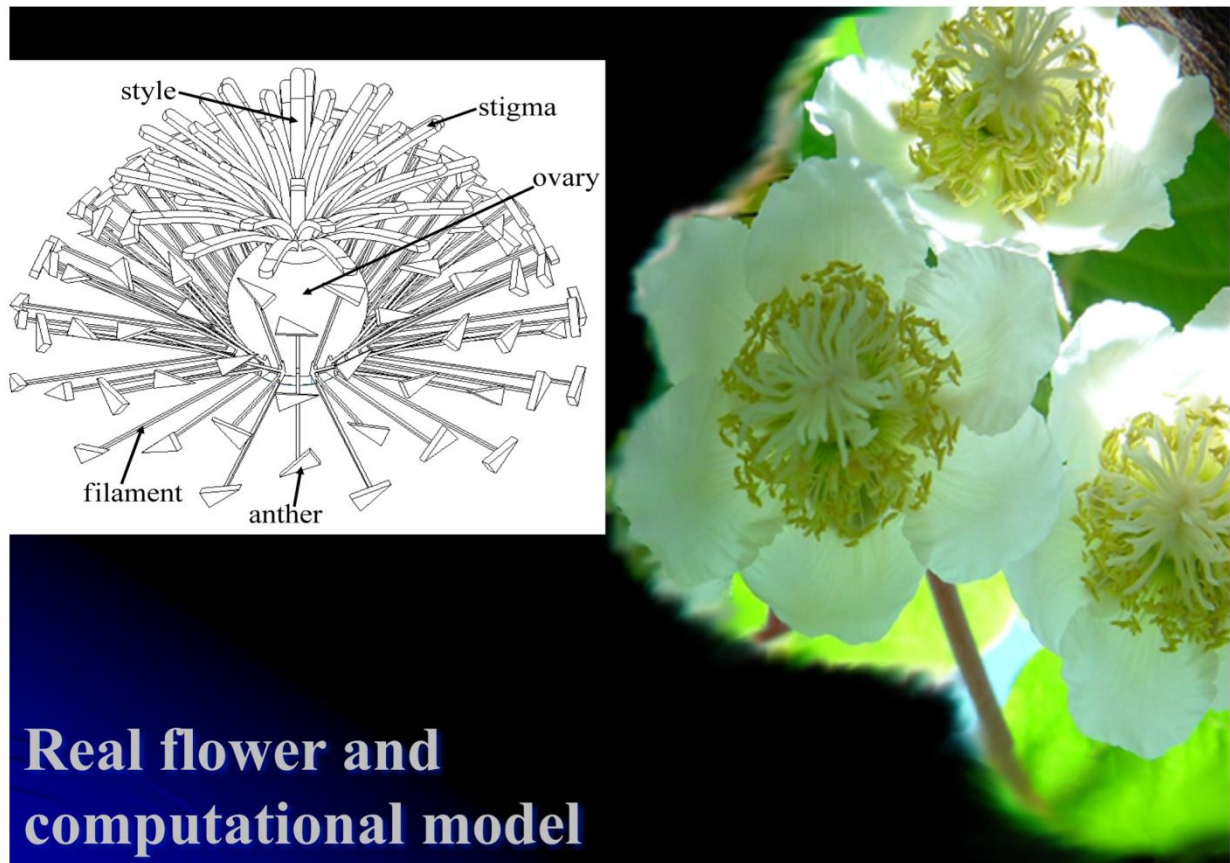

Experimental and modelling of air jet pollination  
both in lab and orchard

It was worthwhile to model the capture of pollen on the female flower, from either the wind, or a blower. This was done with a CFD package. Some of the beauty of the flowers has come through in Michael's rendering of the stigma and style detail in the computer model.

Part of the larger picture for pollination is the air flow pattern around the vine. Optimum conditions were found for pollinating one half of each vine on passing along a row of vines with a blower delivering air carrying pollen grains.

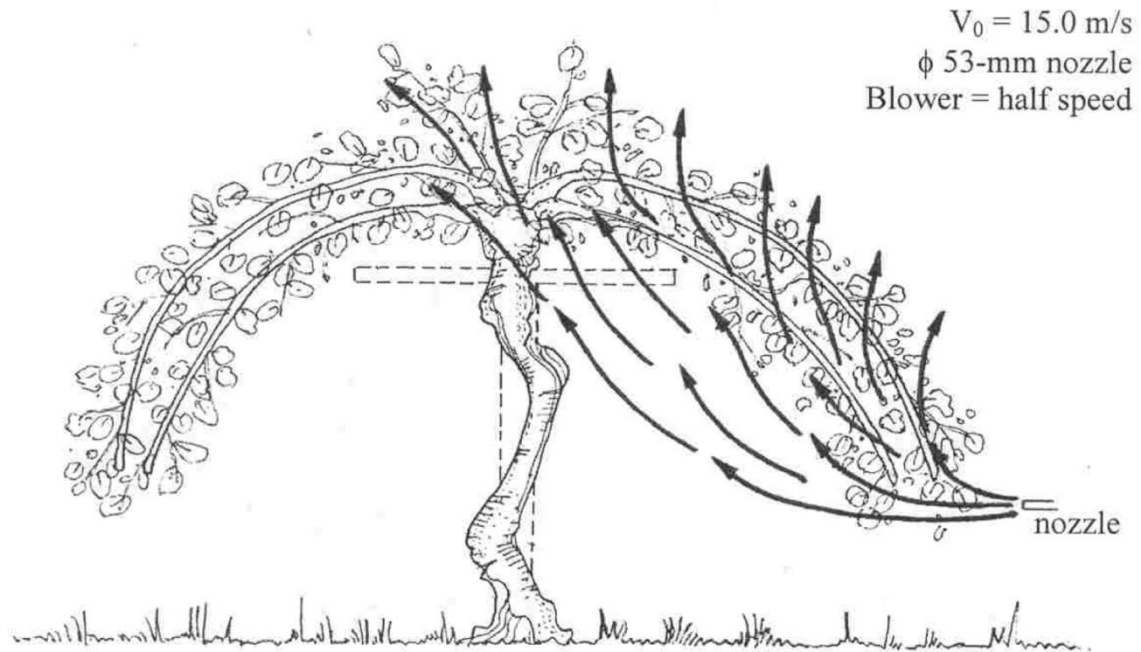

### Optimum configuration for pollinating a kiwifruit row using a tractor-supported nozzle & blower

This optimum was tied into the expected efficiency of the flowers for collecting pollen, as a function of local air velocity.

This simulation shows that the pollen may get more than one pass through the stigma bundle, by circulation within the petal cage.

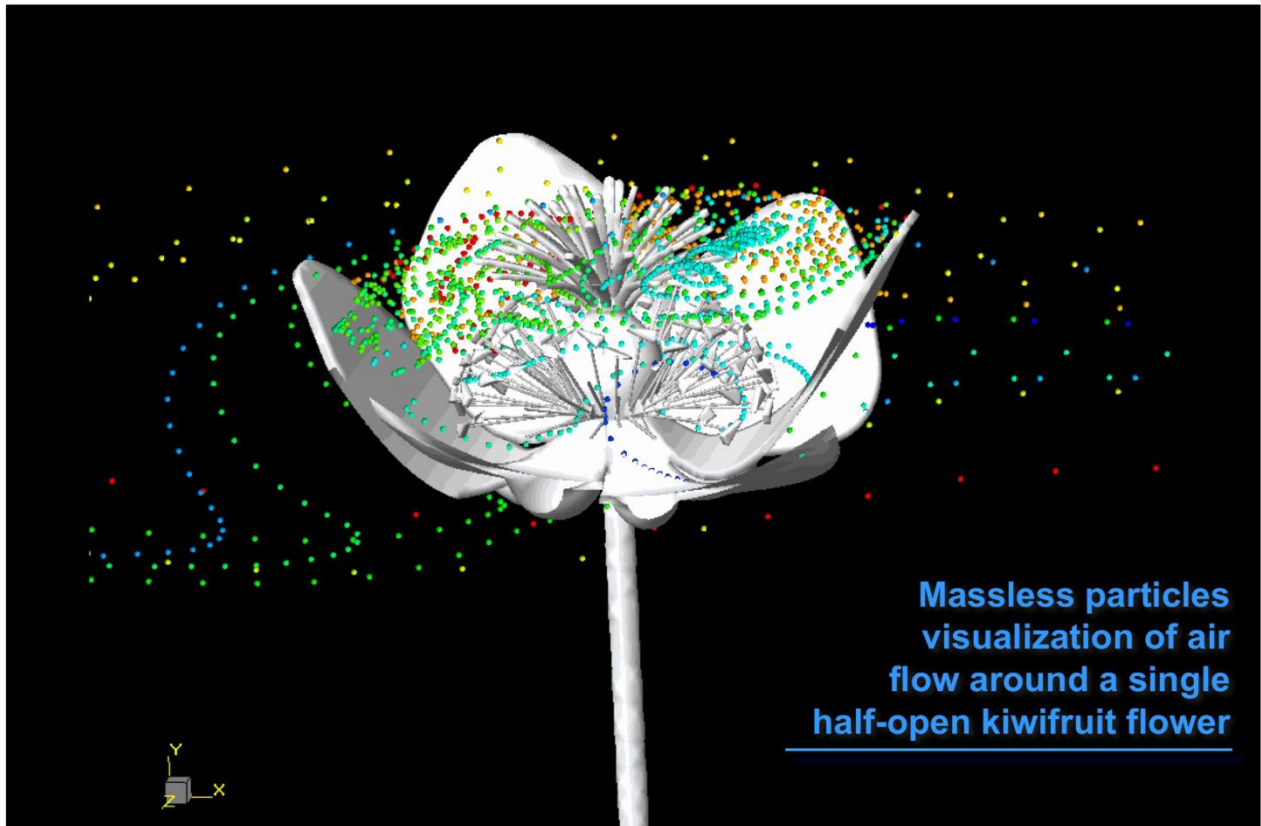

Petals help the airflow **circulate** around the stigma  
Kiwifruit pollen are 22 microns dia and not massless!

The finer interaction is with individual stigma, by impact or curling flow.

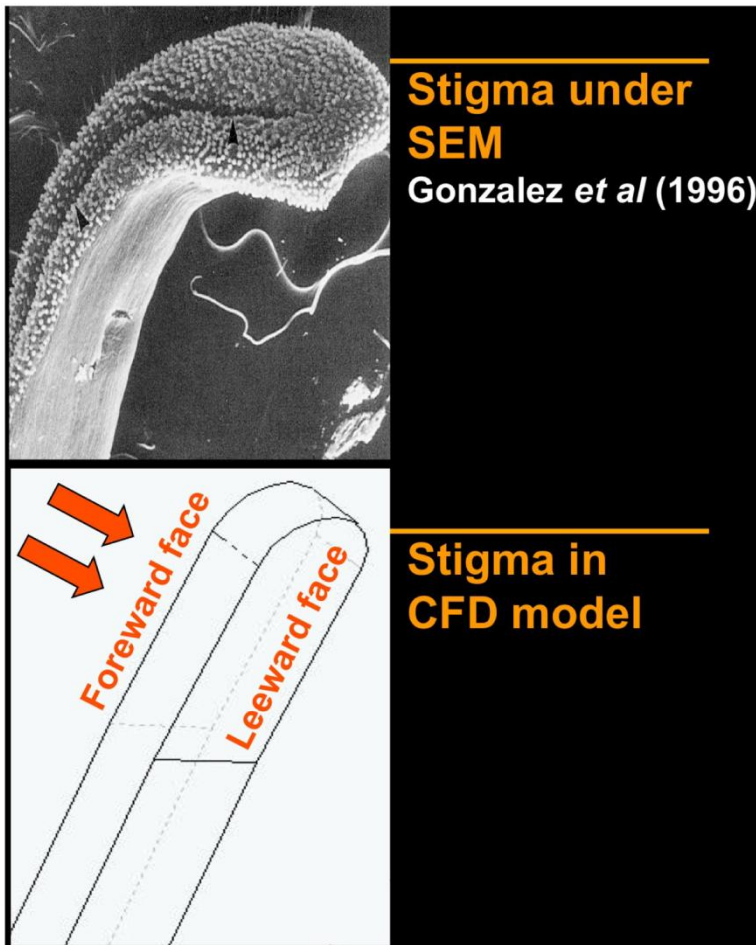

Finer scale flow around individual stigma

Low vel, collect leeward

High vel collect forward

31

By varying the air velocity, an efficiency dependance could be determined.

Our simulations showed higher efficiencies of pollen collection with air jets rather than with wind.

Wind often does not provide enough pollen over the 6 days to yield a full-sized fruit.

Wind pollination (1 m/s) capture efficiency **0.3%**

Expect only **800** pollen collected  
(Need 6000 to achieve 100 g fruit)

Time gap female to male flowers

Some air-jet efficiencies

1 %

3 %

Frontal flow best efficiency

Air jet velocity [m/s]	Recommended pollen feed rate [mg/s]
0.5	6.1
1.0	2.9
2.0	1.8
3.0	1.4

**Air jet better than wind! This is now commonly used by growers.**

# Cyclone dust collection

1975-2000  
With Ross Wakelin



The collection valve of a cyclone, with blower,  
cement works, UK



Ross Wakelin did much experimental work with cyclones to underpin some of the results shown below. I did much consulting in this area, both in NZ and the UK.

Most industrial sized cyclones can be seen only in parts, because they are built and accessed over many storeys. The one above shows a bottom valve just above the floor, with a cone starting above that, and a dust collection bin beneath the floor.

Cyclones for collecting  
wood fibre particles from air

20 m high



This pair of cyclones were not enclosed in a building, and so can be seen over their 20 m height. They are part of a wood fibre plant (Nelson).

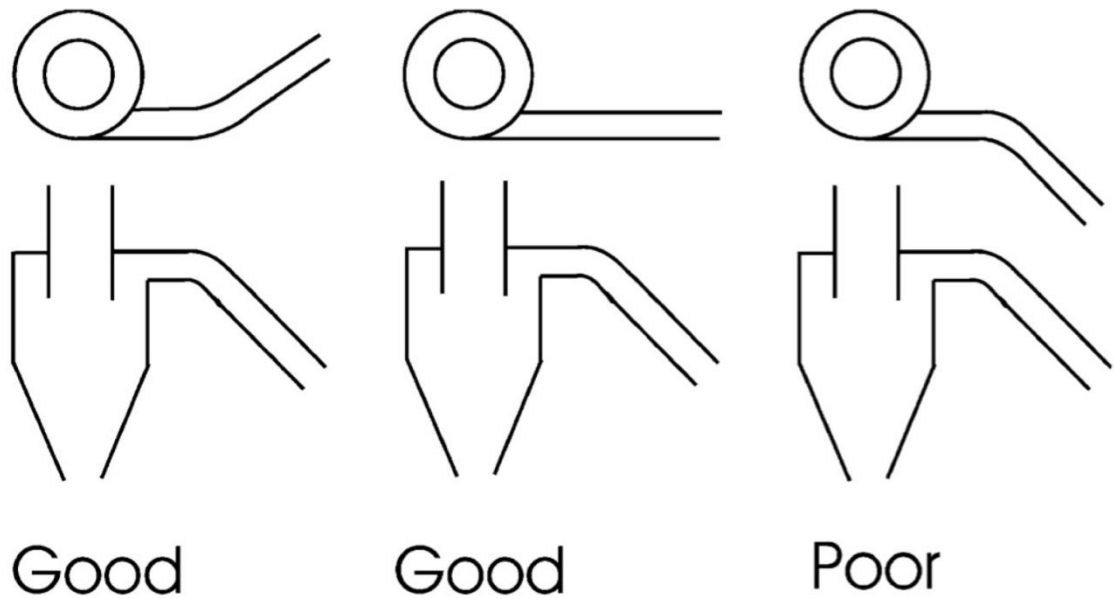

Fig. 1. Plant scale coal dust cyclone configurations.

**Huge variability in dust collection efficiency** for same cyclone design, but different inlet pipe bends

**Good** is > **95%**. **Poor** is **80-90 %**, i.e. **> 2 times emission**

~

A plant on the West Coast burning coal dust reported for different cyclones large variation in dust loss to the environment (> 2 times) even though the same geometry of cyclone was used for all.

The configuration of the piping leading to the cyclones was different, as shown here.

In order to begin to think about what may be causing these differences in performance, we must present the idealised model for a cyclone dust collector. This figure shows the idealised gas flow and particle flow for a conventional "return-flow" cyclone.

The vortex generated by the tangential entry continues down to the bottom of the cyclone, and then returns up through the centre, where the gas exits. Instead of this ideal behaviour where most of the dust is collected at the bottom, sometimes the dust can short-circuit through boundary layer flows across the roof. These boundary layer flows are set up because of the radial pressure gradients due to the vortex.

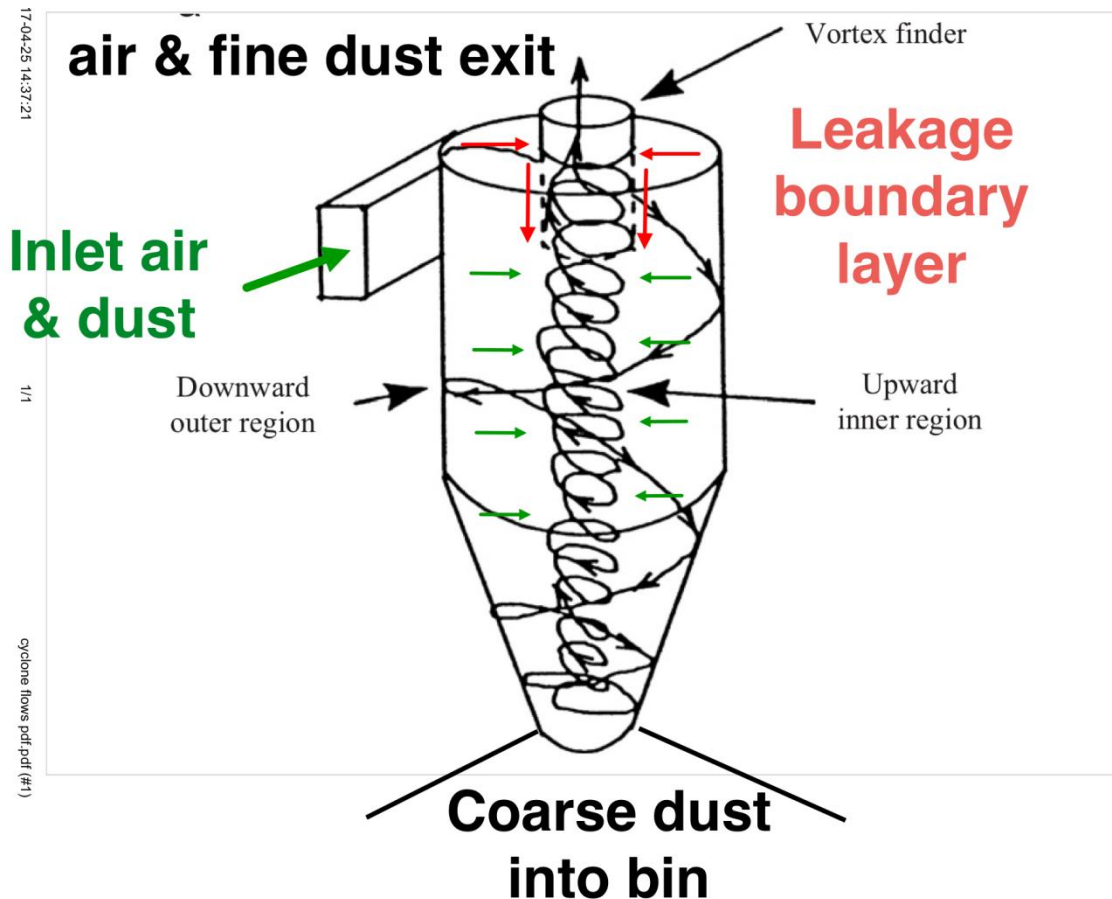

**Note: large dust leakage near entry to cyclone**

We were introduced to a large industrial problem, where the consent to operate the plant was at risk, solely because of emission to the environment. A set of cyclones collected wood fibre, each exhausting to the air environment, but with radically different emissions to the environment. The emissions were largely tiny balls of fibre, and the poor performing cyclones emitted more than 10 times that of the well-performing cyclones.

Again, the entry of the cyclones differed. "Poor" had an inlet air flow up and through a bend into the cyclone, and "Good" had an inlet air flow down into a bend and into the cyclone.

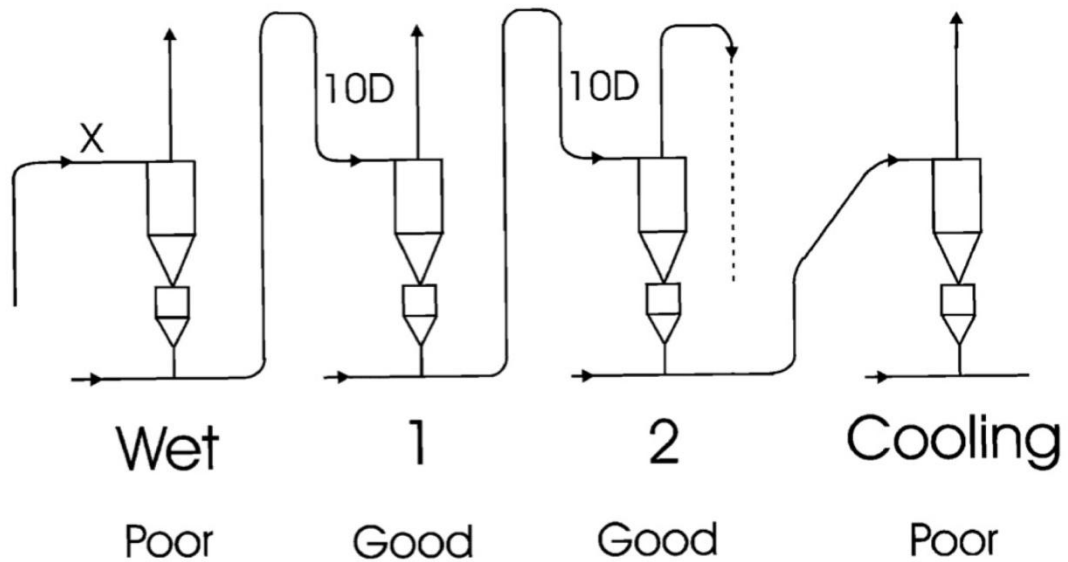

Fig. 2. Layout of cyclones in each of the wood pulp drying lines in a pulp mill.

**Poor** has > 10 times emission of **Good**  
**Plant threatened with closure**

Without thinking much about the emission mechanism, we could replace a "poor" type of entry with a "good" type. Thus we could replace the "up and bend" entry A with a "down and bend" entry as in B in the figure, but this was too expensive!

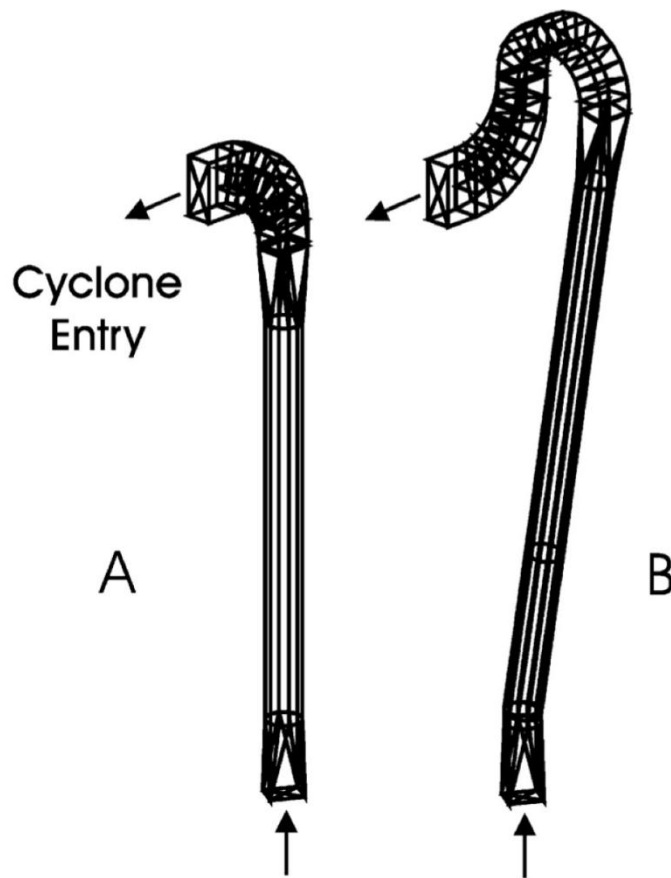
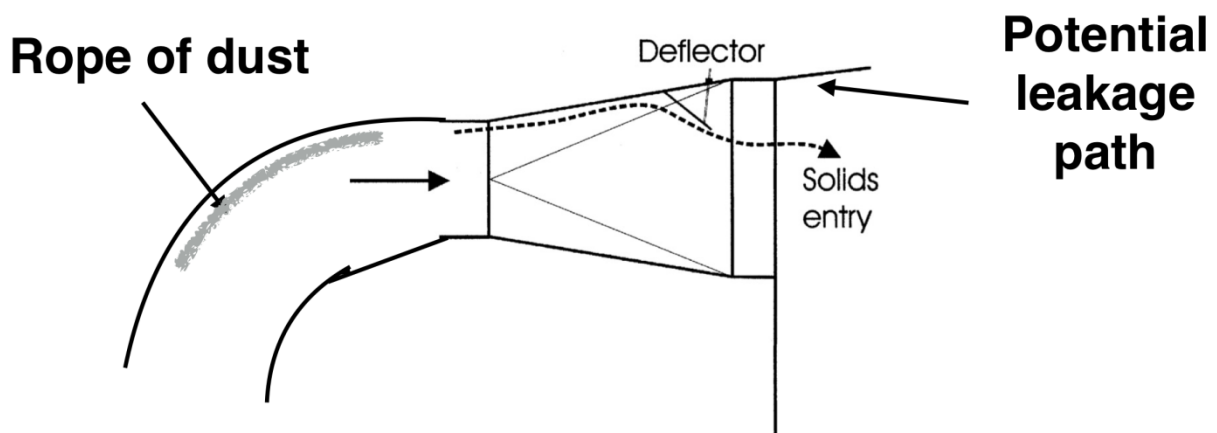

Fig. 3. (A) Original rising duct entry for the wet cyclone on no. 3 line, and (B) the modified duct including an 180° bend and downward 90° bend into the cyclone. The duct diameter is 950 mm, and approximately 20 m long.

**First solution too expensive (>50k \$)**

What was behind the problem we were trying to fix? The dust had formed a "dust rope" along the outside of the bend, by being thrown against the outside and aggregating there. This dust rope persists to some extent and for the upcoming flow, the rope was at the top of the inlet where it could transfer across to the exit tube (bad). For the rope forming in the bend of the downcoming flow, the rope was at the bottom of the inlet where it could be redispersed into the vortex flow (good). Now we have a good guess at the cause of the emission, we can design a cheaper fix.

A cheaper fix was to install a deflector plate at the top of the inlet, to move the rope down away from the cyclone ceiling.



Deflector cost several k\$ only, reduced emissions to only  
 3 % of previous  
 and was **adequate for the plant to stay in operation**

The rope made of fibrous dust is expected to be more persistent than the rope made of coal dust, so the improvement from bad to good is more impressive for the fibrous dust.

This project on ball lightning started as James Dinniss's final year research project, and he did such a good job, that he was able to be a coauthor with me of an article in *Nature*.

# Ball lightning

2000-2010  
With James Dinniss

First, some slides of a video taken of a moving luminous ball in a car park in Mexico. The manager of an electronics factory sent me this (after we had become known by publishing the *Nature* paper).

A partly lit walkway is in the background.

The ball was observed for a couple of minutes. See the small arrow showing the ball and the enlargement on the LHS.

See the succeeding photos where the reflection from the walkway lamp shows through the ball, indicating that it is transparent.



These video frames are rare. There are more than 10,000 catalogued ball lightning observances, and very few have been videoed or even photographed.

## Ball is weakly luminous, transparent



What is it? Problem reaching back 300 y

This following slide is a "ball" at the extreme end of size - around 100 m across, seen for about 7 minutes by a Park Ranger in Queensland, Aus.



# Queensland fireball – BL?

Bychkov, Abrahamson Trans Roy Soc A 2002



The following slide shows the same area in daylight the following day. The comparison emphasises the large scale of the luminous "blob".

# Queensland landscape by day

Courtesy of Brett Porter, Queensland National Parks and Wildlife Service



Here are the elements of our theory of ball lightning - starting with a normal lightning strike on soil, forming a channel through the soil, that releases a vortex ball made up of the hot silicon-bearing vapour. The channel is often several m in length, sometime reaching underground water, and the molten tube of silica around the channel, frozen after the event, is often seen by geologists who call it a "fulgurite".

## “Fluff-ball” model Nature 2000

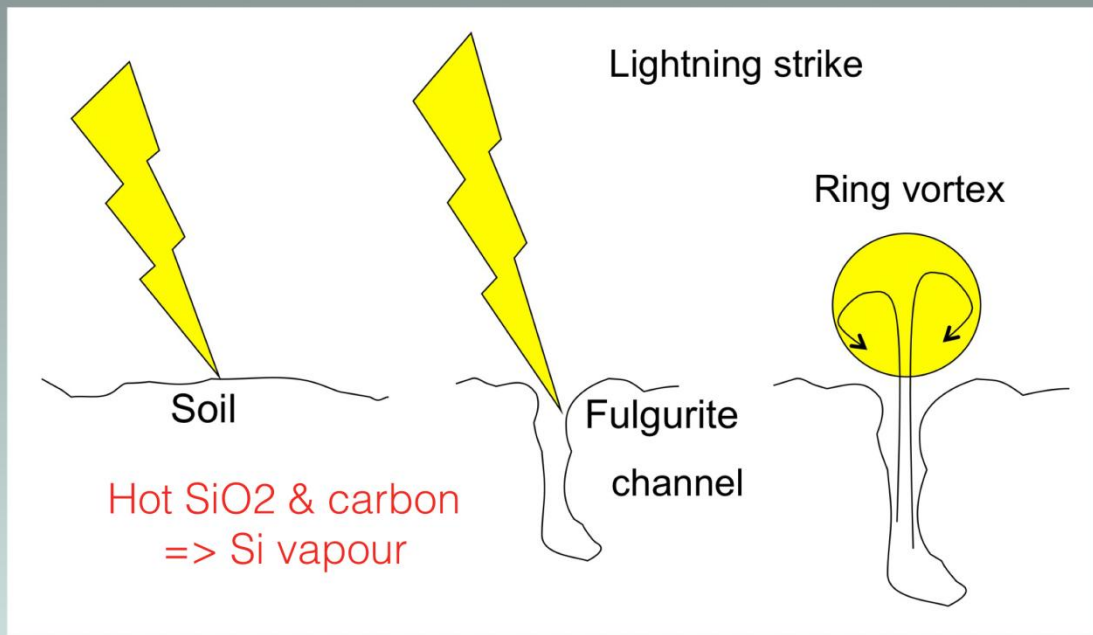

John Abrahamson and James Dinniss

The proposed chemistry of the ball-lightning event: Heating silica with carbon to high temperatures produces silicon (element). The Si vapour condenses to form Si nanoparticles, that aggregate into chains (as found by our lightning-simulation spark experiments). The Si nanoparticles then oxidise slowly (over seconds or even minutes) and emit the light that we see.

The oxidation in air is slowed by the formation of a SiO<sub>2</sub> layer on the surface of the nanoparticles, through which O<sub>2</sub> must diffuse for oxidation to continue.

# Fluff-ball chemistry

- Oxidation slowed by oxide layer

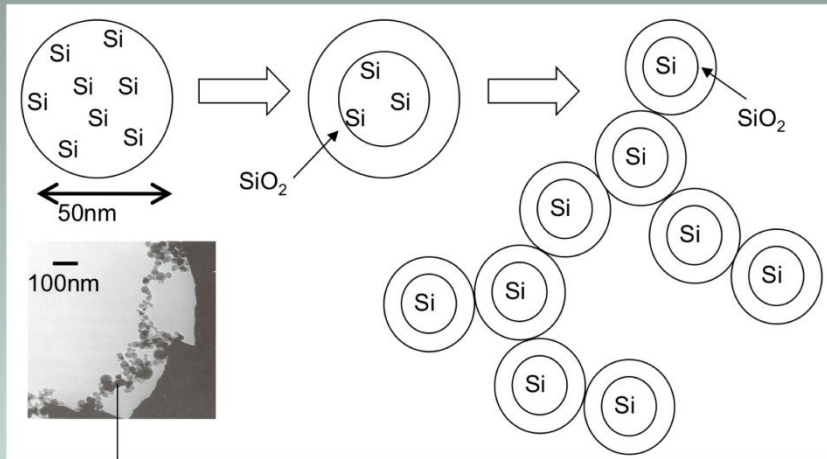

nanospheres in chains, sampled after spark

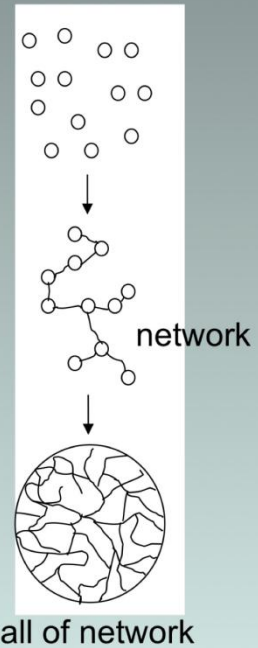

ball of network

Below is a photo of the spark experiments we did on soils, showing the ring vortex of the hot gases.

## Simulated lightning strike on soil

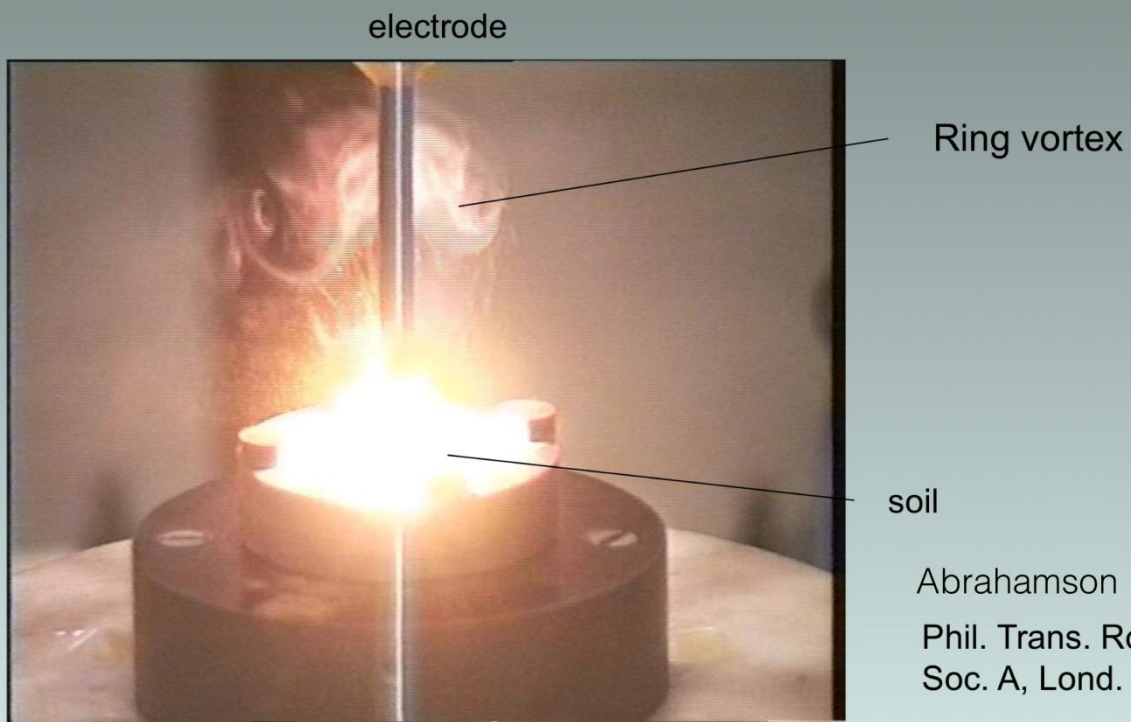

Abrahamson  
Phil. Trans. Roy.  
Soc. A, Lond. 2002

This next project was a continuation of the findings from the ball lightning work. John Marshall, an astrophysicist from NASA, and Payel Bagga, my PhD student, joined forces with me to investigate the reasons for the chains of particles seen in the experiments.

# Electric dipole aggregation

2000-2015

With John Marshall (NASA) & Payel Bagga

We realised that particles containing *magnetic* dipoles resulted in chains. Fig (a) shows chains from Fe particles. It appeared that *electric* dipoles could also make chains. John had seen chains of sand forming in his microgravity experiments on the international space station (see (b)). In (c) we see the chains formed from our ball lightning experiments.

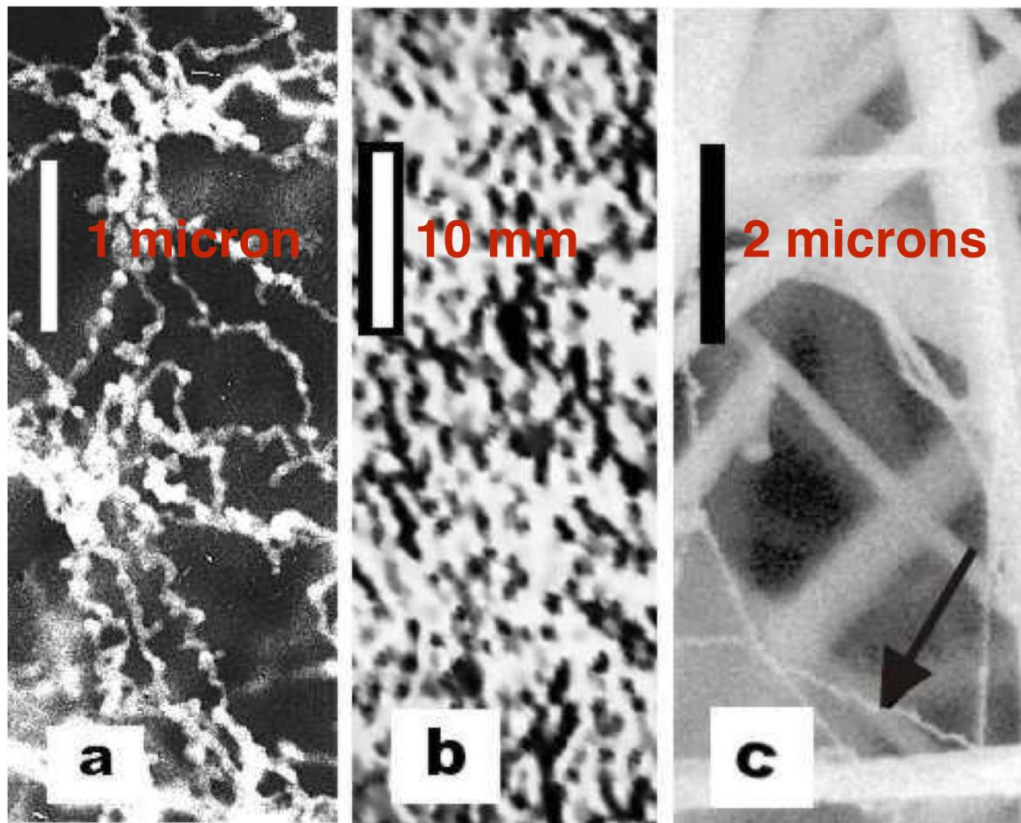

Chains built up from dipole aggregation  
 (a) Magnetic Fe (b) SiO<sub>2</sub> electric (c) spark on soil

If one has particles in a heap, and then separate them from each other, charges are left on the surfaces that have separated (+ve patch of charges on one surface, -ve patch on the other). Thus dispersion of dust from a heap into the air will make patches of charge on different areas of each particle. In general, both net charge and dipoles will form on each particle, from this tribocharging mechanism.

Another way to form dipoles is to oxidise the surface, generating defects that may be +ve or -ve in the oxide layer, that can be randomly distributed. This mechanism (with lower expected charges) can be important for nanoparticles.

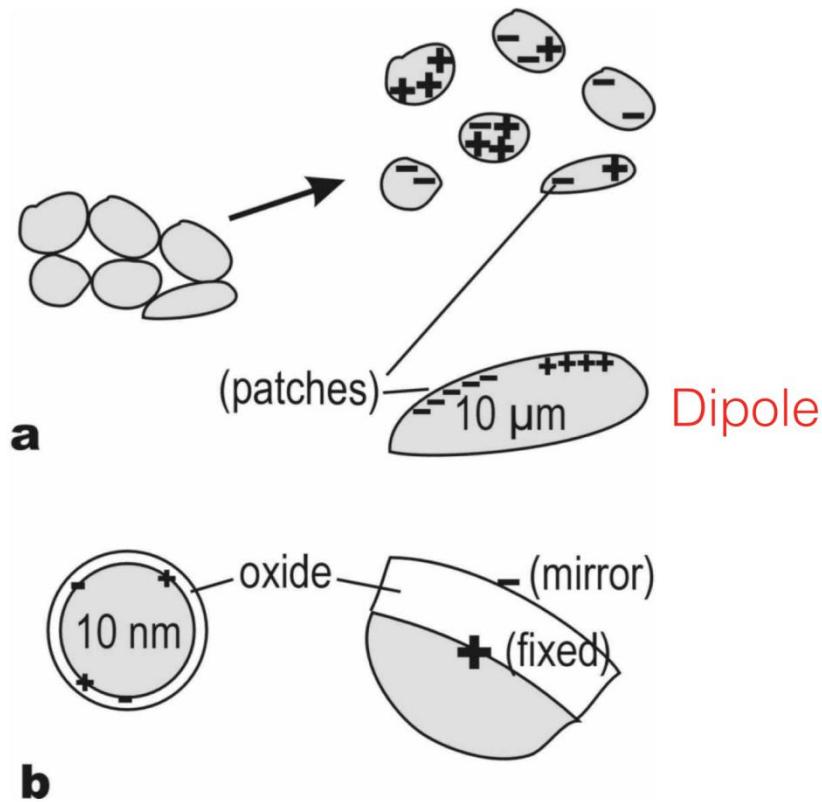

Creation of electric dipoles on particles  
 (a) dispersion into gas (b) oxide layer formation

Dipolar particles build their pulling power when the number of dipoles connected builds up - they become an even more effective particle collector. Single pole particles (either positive or negative) cancel out when they combine, so *do not lead to large aggregates*.

Both my collision papers have been used to estimate aggregation in an interesting problem - the formation of planets. The early turbulent paper did not provide the required rate of aggregation according to the conditions early in our solar system, but the later dipole paper provided a part answer. The other part of the answer was a dipole formed by a slightly non-symmetric ice coating on the particles.

For the same charges, dipoles affect smaller areas than do  
monopoles

*however*

Positive is attracted by negative, and cancel out when they meet

Dipoles add up => large dipoles for chains of dipoles

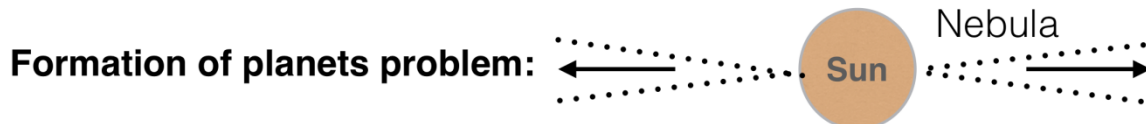

**How does space dust aggregate to start planets?**

Cosmologists Wilkinson et al. (2008) have used my **1975** paper in  
estimating aggregation rates in the early solar nebula

- **not sufficient** to explain the planets.

Cosmologists Wang et al. (2005) have used our **2001** dipole paper.

With the right dipoles,

- the rates **are sufficient!**

The dipoles they proposed are formed from thin cold ice layers on  
the particles.

The last of my projects is very different, and I have been fortunate to have gelled with Stuart McKenzie who is my CEO in our business venture.

# New negative electrodes for Pb-acid batteries

2010-present  
With Stuart McKenzie

Our basic idea was to take the cheapest widely available battery and to improve its performance to make it suitable for the new market of hybrid vehicles. We replaced the traditional lead grid of the negative electrodes with a much finer treated carbon fibre-based fabric. The example shown is a non-woven carbon felt. The difficult tasks were connecting lead (physically and electrically) to the carbon fibres, and loading the lead-based particle paste fully into the fabric.

## ArcActive Electrode: A Carbon Fibre-based "Grid"

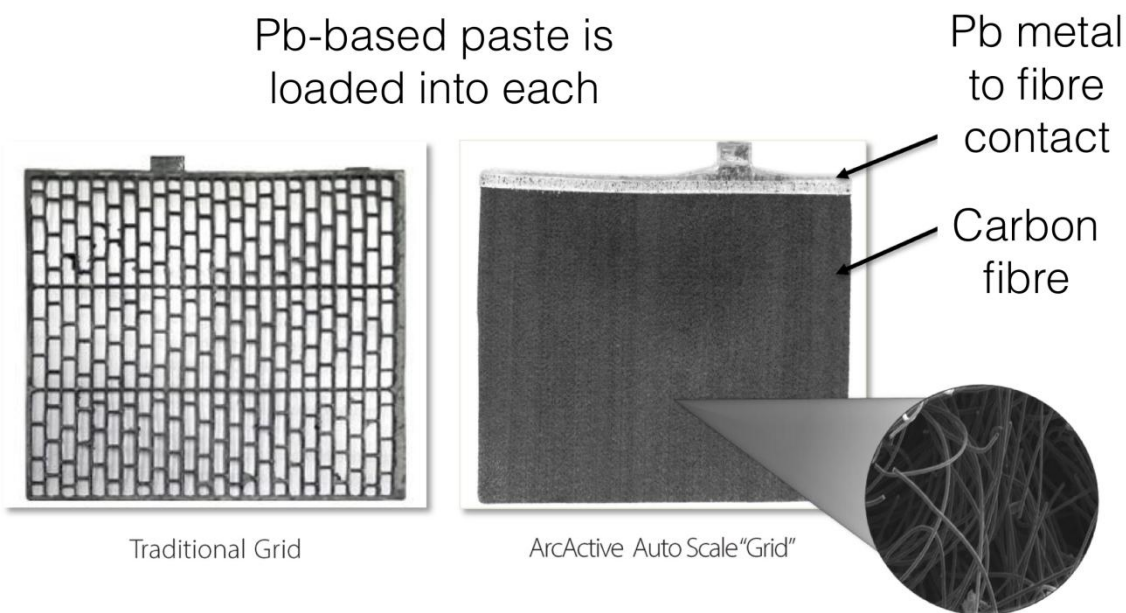

ArcActive vs traditional electrodes



The key functions of a battery in a hybrid vehicle are to allow the engine to stop and go many times ("Stop-start") and to take in current easily when braking ("Regenerative braking"). The latter function needs the starter motor to act as a current generator while doing some of the braking, then feeding this current into the battery.

The critical function is "dynamic charge acceptance" or "DCA" - this is the charging current accepted over the short period of braking (around 5 s).

## Target market "medium hybrid vehicle" (MHV)

stop-start and regenerative braking

The CO<sub>2</sub>/fuel savings of the MHV are tied to the charging (DCA) performance of the battery



The car-makers want a steady ability to take in charging current (see target level of DCA). Existing lead-acid batteries, including those currently best suited for hybrid use, achieve this level only when the car is first purchased. After that, the performance drops away to 10 to 20 % of the target after several weeks.

It is known that the negative electrodes cause this fall-off, because the particles that do the charge accepting *aggregate* (lose their number and enlarge). This means the electrode loses surface on which to do the charge accepting reaction, and the charge acceptance is lower.

We fortunately have a better negative. The battery made with ArcActive negatives performs close to the target, and stays there, except for dropping temporarily after long periods of inactivity. (See the "airport test" of 1 month of pause in the DCA test below).

## ArcActive DCA versus traditional (State-of-the-Art) Lead Acid Batteries

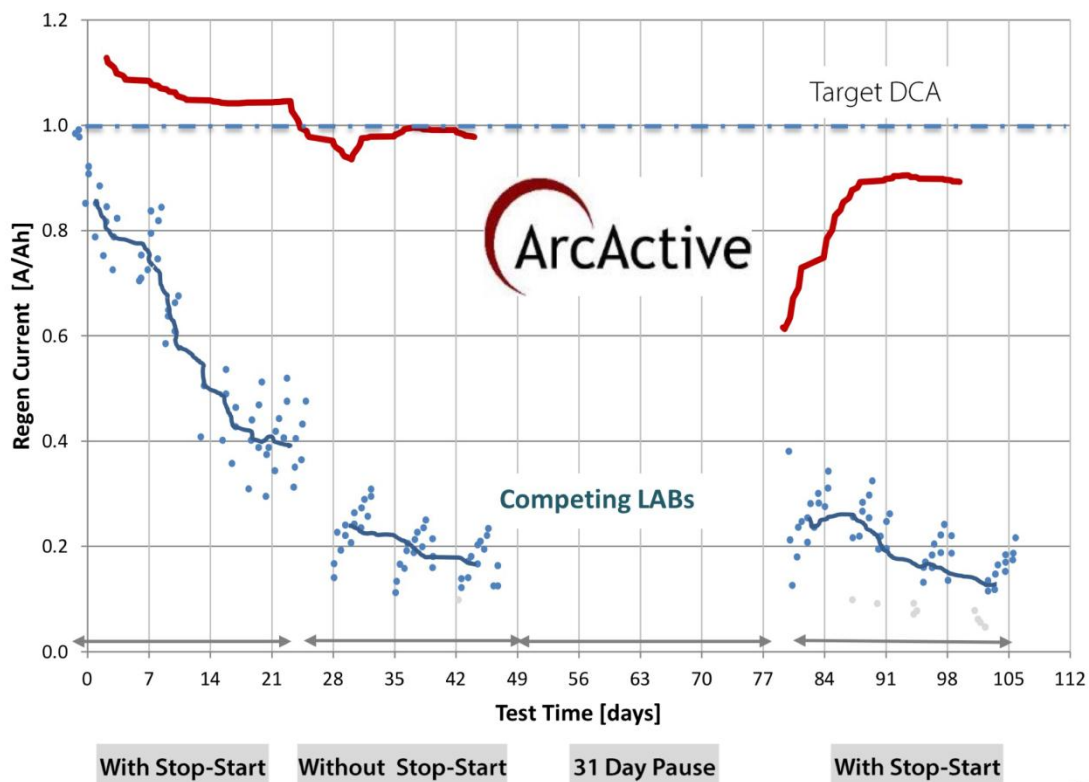

The active mass of this traditional negative electrode after much stop and start action has particles 3 to 5 microns as seen by a scanning electron microscope (SEM).

## Traditional Pb electrode

### Micron-sized active mass

Relatively large micron-sized Pb-based particles in traditional negative electrode =>

*poor charge acceptance*

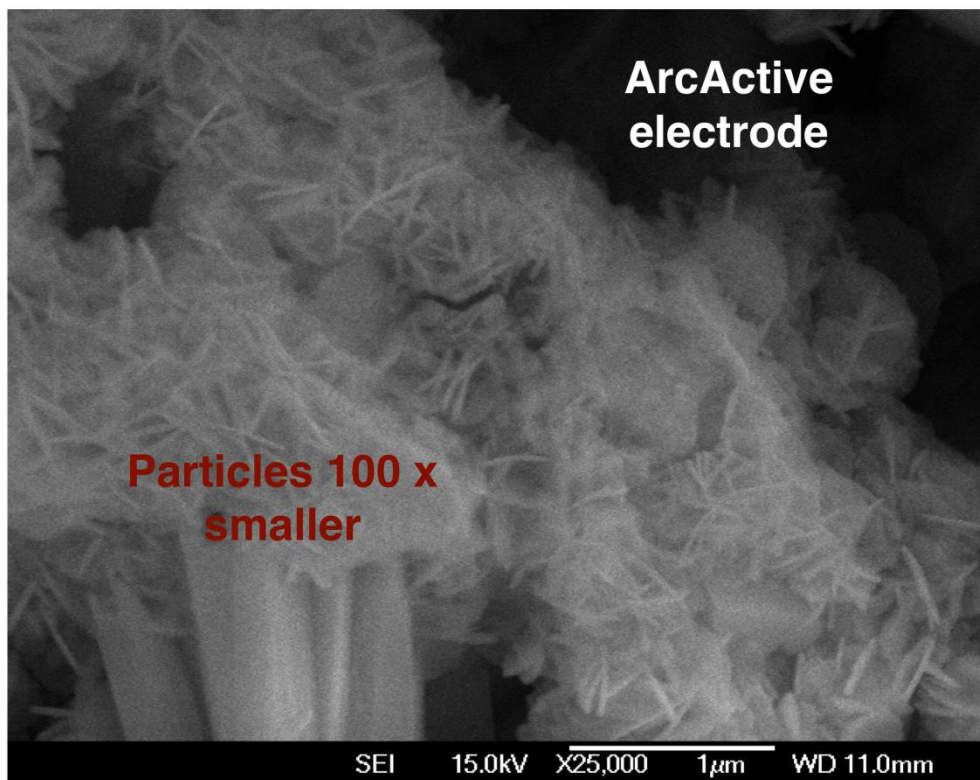
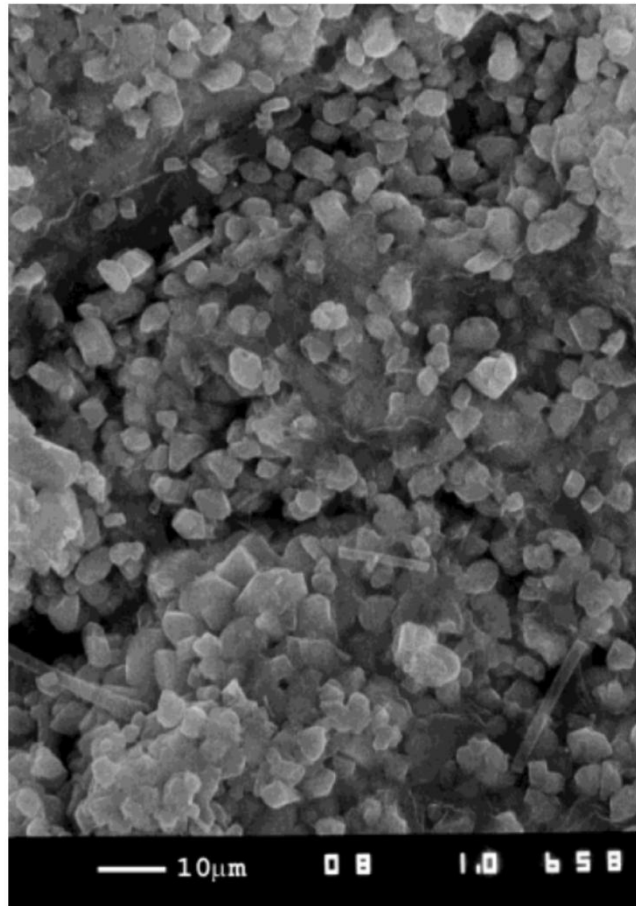

Nanosized Pb-based active material on ArcActive negative electrodes => *high sustained charge acceptance*

The active mass of this ArcActive negative after similar duty has particles roughly 20 nm of thickness (1/100th of the size). It is also robust and recovers from difficult tests much better than the traditional negative.

The market is driven both by economics (saving fuel) and pollution regulations (g CO<sub>2</sub>/km). The market worldwide is expected to rise from 100 m batteries / y to 300 m / y over the next decade.

The main competition is from Li-ion, with both more expense (more than double) and danger (battery fires, explosions).

## ArcActive "addressable market" (Based on tightening emission regulations worldwide)

### Production rate of MHV batteries

2020	100 m / y
2030	300 m / y

*"Pb-acid is dead unless improve DCA"*  
(Car-maker battery expert 2017)

Some business points - our homework (e.g. in intellectual property, production techniques) has been done, and the technical challenges have been as demanding (and interesting!) as that of any of the other projects I have described.

Full production is expected to start in a couple of years, and we expect it to be NZ based.



Performance world-leading for hybrid vehicles

Production methods continuous and fast

Robust electrodes

Economical

Working with major battery makers worldwide

Covered by patents

All of these works have resulted in some advance in insight, but I have not shown you the failures! All projects take time, and bets are always on whether the time is worth it. My family has been very tolerant with my time away from them.

*None* have been supported by specific science funding, 3 were supported by industry, but all were supported by general research funding and technical help from the University of Canterbury through the Chemical and Process Engineering Department. Miles Kennedy kick-started this off for me.

In the end, it is the momentary pleasure of realising some advance that one works for, whether the advance comes from oneself or from one's mates.

## References:

### Preamble

Popper, K. R. (1968) "*The logic of scientific discovery*" Hutchinson, London (translation of his original "*Logik der Forschung*" (1934), 480 pp.

Magee, B. (1975) "Popper" Fontana/Collins Modern Masters, 110 pp. Some of my PhD's read this little book.

### Carbon nanotubes

Abrahamson, J. (1971) "The reactions of coal in a high intensity electric arc". PhD thesis, University of Canterbury, N.Z.

Abrahamson, J. (1973) "The surface energies of graphite". *Carbon*, **11**, 337-62.

Abrahamson, J. (1974) "Graphite sublimation temperatures, carbon arcs and crystallite erosion". *Carbon*, **12**, 111-141.

Wiles, P.G. and Abrahamson, J. (1978) "Carbon fibre layers on arc electrodes – their properties and cool-down behaviour". *Carbon*, **16**, 341-49.

Wiles, P.G. (1979) "The production of acetylene by a carbon arc" PhD thesis, University of Canterbury, NZ.

Abrahamson J., Wiles PG., Rhoades BL. (1979, 1999) "Structure of carbon fibres found on carbon arc anodes". *Carbon*. **37**(11) Nov. 1999: 1873-4. (Republication of a paper presented to a 1979 Carbon conference in the US, because of historical significance).

Davies, C.E., Abrahamson, J. (1983) "Limit to erosion rate in a high current carbon arc". *Ind. & Eng. Chem.*, **22**, 226-30.

Ball, P. (2001) "Roll up for the revolution" *Nature*, **414**, 142-144.

### Turbulent aggregation

Abrahamson, J. (1975) "Collision rates of small particles in a vigorously turbulent fluid". *Chem. Eng. Science*, **30**, 1371-79.

Wilkinson, M. (2008) "Stokes trapping and planet formation". *The Astrophysical J. Supplementary Series*, **176**, 484-496. (See eqn. 3).

### Soot formation

Abrahamson, J. (1977) "Saturated platelets are new intermediates in hydrocarbon pyrolysis and carbon formation". *Nature*, **226**, 322-27.

### Snow avalanches

Conway, H.B. (1985) "Snow avalanche release" PhD thesis, University of Canterbury, NZ.

Bell, M.J. (1993) "Wind Pumping in a Snow Pack related to Atmospheric Turbulence" PhD thesis, University of Canterbury, NZ.

Conway, H., Abrahamson, J. (1988) "Snow slope stability – a probabilistic approach". *J. Glaciology*, **34**, 170-7.

Conway, H., Abrahamson, J. (1986) "A field test to assess snow-slope stability". *J. Glaciology*, **32**, 535-7.

### Kiwifruit pollination

Hii, M. (2003) "Kiwifruit flower pollination" PhD thesis, University of Canterbury, NZ.

Hii, M.J.W., Abrahamson, J., Jordan, P.J. (2003) "Modelling of air flow and pollen collection by a single kiwifruit flower under wind and an air jet". *Third International Conf. on CFD in the Minerals & Process Indust.*, CSIRO, Melbourne, Aust. 10-12 Dec., 2003.

#### Cyclone dust collection

Wakelin, R.F. (1992) "Vortex Breakdown in Dust-Collecting Return-Flow Cyclones" PhD thesis, University of Canterbury, N.Z.

Abrahamson, J., Jones, R., Lau, A., Reveley, S. (2002) "Influence of entry duct bends on the performance of return-flow cyclone dust collectors". *Powder Technology*. **123**, (2-3) 126-137.

#### Ball lightning

Abrahamson J., Dinniss J. (2000) "Ball lightning caused by oxidation of nanoparticle networks from normal lightning strikes on soil". *Nature*. **403**, (6769) 519-521.

Abrahamson, J. (2002) "Ball lightning from atmospheric discharges via metal nanosphere oxidation: from soils, wood or metals". *Phil. Trans. Roy. Soc. Lond. A*. **360** (1790) 61-88.

Abrahamson, J., Bychkov, A.V., Bychkov, V.L. (2002) "Recently reported sightings of ball lightning: observations collected by correspondence and Russian and Ukrainian sightings". *Phil. Trans. Roy. Soc. Lond. A*. **360** (1790) 11-35.

#### Electric dipole aggregation

Abrahamson, J., Marshall, J. (2002) "Permanent electric dipoles on gas-suspended particles and the production of filamentary aggregates". *J. Electrostatics*. **55** (1) 43-63.

Bagga, P. (2009) "Measurement of electrostatic dipoles and net charges on air-dispersed particles". PhD thesis, University of Canterbury, N.Z.

Bagga, P., Abrahamson, J., Marshall, J. (2008) "Measurement of electrostatic dipoles and net charge on dust particles suspended in air." Chemeca 2008 Conference, Newcastle, Australia, 28 Sept- 1 Oct, 12 pp.

Wang, H. (2005) "Sticky ice grains and planet formation: Unusual properties of cryogenic water ice." *The Astrophysical J*. **620**, 1027-1032.

#### New negative electrodes for Pb-acid batteries

Abrahamson, J. McKenzie, S. et al. (2014) "Lead acid negative electrodes built around carbon felt current collectors – at the scale for hybrid cars" 15<sup>th</sup> European Lead-acid Battery Conference, Edinburgh.

McKenzie, S., Abrahamson, J. (2015) "Sustainable DCA via carbon fibre grid." In conference Kraftwerke Batterie, 28 April, 2015, Aachen, Germany.