

MICROWAVE CHEMISTRY — AN APPROACH TO THE ASSESSMENT OF CHEMICAL REACTION HAZARDS

P.M. Gillespie

AstraZeneca, Silk Road Business Park, Macclesfield SK10 2NA

Although being used increasingly in the research and development laboratory there are few examples of large-scale microwave assisted synthesis. A feasibility study for the development of plant-scale microwave reactors is currently being carried out in AstraZeneca, one of the major considerations for which is that of operating safety. In this paper an approach to the assessment of chemical reaction hazards is discussed, covering the basic theory of microwave/solvent interaction and addressing the issues required for the generation of a basis for safe operation of large-scale microwave processes.

INTRODUCTION

Microwave chemistry is being used increasingly in the research and development laboratory with several potential benefits being reported over “normal” chemistry. These include reduced reaction times, reduced quantity or elimination of solvents and catalysts and cleaner reactions, which can lead to reduced operating costs and more environmentally friendly processes.

Although many examples of these benefits have been reported on the laboratory scale there are few examples of large-scale synthesis. One such reactor was a one-off design built by French company Sairem, in collaboration with BioEurope and De Dietrich. The 1 m³ batch recycle reactor, using a 6 kW microwave generator, is used to make Laurydone, an active ingredient in cosmetic products. The benefits in use of microwaves included a 40% reduction in power consumption, a factor of 5 reduction in processing time and removal of the solvent and catalyst.

A feasibility study for the development of plant-scale microwave reactors is now being carried out within AstraZeneca. As well as the not inconsiderable engineering challenges involved, one of the major considerations is that of operating safety and in particular the associated chemical reaction hazards. Early consideration of the hazards is essential to a) highlight any potential major hazards and b) to provide guidance towards the most inherently safe reactor system design.

MICROWAVE/SOLVENT INTERACTION — BASIC THEORY

When considering what the basis of safety for operation of a large-scale microwave reactor might be, one needs a basic understanding of how microwaves interact with solvents, reagents, etc., and therefore what additional chemical hazards they may introduce. Are they merely an efficient heating source or do they actually affect the reaction chemistry itself?

Microwaves are electromagnetic radiation of wavelength 1 mm to 1 m corresponding to frequencies in the range 300 MHz to 300 GHz. All domestic microwave ovens operate at 2.45 GHz which is one of a few permitted frequencies regulated to avoid interference with e.g. RADAR and telecommunication applications. Within the microwave frequency range the electric field component interacts with polar molecules resulting in dielectric heating. Many excellent publications exist covering the fundamental theory of this phenomenon^{1,2} but the two main mechanisms are dipolar polarisation and ionic conduction.

A polar molecule such as water will attempt to align itself with an applied electric field by rotation, which in liquids is impeded by the presence of other molecules. At low frequencies the molecule will align in phase with the irradiation while at high frequencies the molecule doesn't have time to respond, no energy is transferred in either case and therefore no heating occurs. In the microwave region a polar molecule responds to, but does not have time to precisely follow the applied electric field. This failure to keep in phase results in energy loss via friction and collision with other molecules giving rise to dielectric heating. One would expect the ability to absorb microwave radiation to increase with polarity and indeed absorbance does generally increase with increase in the dielectric constant. The dielectric loss or loss tangent ($\tan \delta$) is a measure of how well a polar material absorbs microwaves (Table 1) and explains why, for example, ethanol heats up more quickly when irradiated than acetone even though both have similar dielectric constant values.

The presence of ions in a solution has a marked effect on dielectric heating rates. For example, tap water subjected to microwave irradiation for a given time at a certain frequency will heat up at a faster rate than pure water. Under the influence of the electric field the dissolved ions migrate through the liquid generating heat energy from an

Table 1. Dielectric constants, loss tangent and relaxation times for various solvents

Solvent	Dielectric constant ² (ϵ_s)	Loss Tangent ¹ ($\tan \delta$)	Relaxation time ¹ (ps)
Water	80.4	0.123	9.04
Dimethylformamide	36.7	0.161	13.05
Acetonitrile	36.0	0.062	4.47
Methanol	32.7	0.659	51.5
Ethanol	24.6	0.941	170
Acetone	20.6	0.054	3.64
Dichloromethane	8.9	0.042	3.12
Tetrahydrofuran	7.5	0.047	3.49
Ethyl acetate	6.2	0.059	4.41
Acetic acid	6.2	0.174	177.4

increased rate of collisions. This effect can generate heating well in excess of that from the dipole polarisation mechanism.

The ability of a polar solvent to absorb microwave radiation is both frequency and temperature dependent. However, since the frequency is usually fixed at 2.45 GHz only the temperature element is relevant. Other factors that influence the rate at which different solutions are heated include; viscosity, polarity, heat capacity and concentration (for ionic conduction).

CHEMICAL REACTION HAZARDS

On the small laboratory scale the basis of safety for operation of microwave chemical reactors is the same as for any other chemical reaction, i.e. ensuring that no chemicals with explosive properties are used, limited operating scale and containment/screening. In fact lab scale microwave reactors are usually designed for containment. Similarly, on scale up, three main parameters need to be examined; thermal stability, reaction heat and gas evolution. However, in addition, for microwave reactors there is the question of the existence and potential consequences of a specific “microwave effect” as well as the potential for superheating of the reaction mass.

THERMAL STABILITY

For normal chemical processes the thermal stability of starting materials, reaction streams, isolated intermediates and distillation residues, etc., is required. Small-scale tests such as differential scanning calorimetry (DSC) and the Carius tube test are used as an initial screen with larger scale tests such as an Adiabatic Dewar test being used where more accurate/precise information on thermal runaway is required. Assuming that there is no “microwave effect” then similar tests would be just as valid for microwave reactions.

However, if this is not the case then a screening test utilising heating of the sample with a microwave source may be required. In a standard Carius tube screening test the oven is heated at a constant rate of 2°C/min between ambient temperature and 400°C which produces a linear rise in the sample temperature when there is no thermal activity. Deviation from this linear “baseline” indicates the onset of exothermic or endothermic activity (Figure 1). An appropriate allowance is then applied for application to large-scale operation.

As far as the author is aware no dedicated microwave sourced thermal stability apparatus is available. However, it is possible that a standard laboratory (ca 10 ml scale) microwave reactor could be adapted for this purpose. Absorption of microwaves for solvents varies with temperature and for a reaction mixture will be complicated by the level of absorption of the reagents, catalysts etc., thus heat-up rate/profile will neither be linear nor easily predictable. A possible way around this may be to use a constant power input to the sample tube up to a predetermined maximum temperature, cooling back to ambient and then “re-running” the test. Subtracting the resulting temperature-time profiles could yield the onset temperature and approximate magnitude of any exothermicity. In fact this re-run subtraction method is frequently used in DSC tests

4

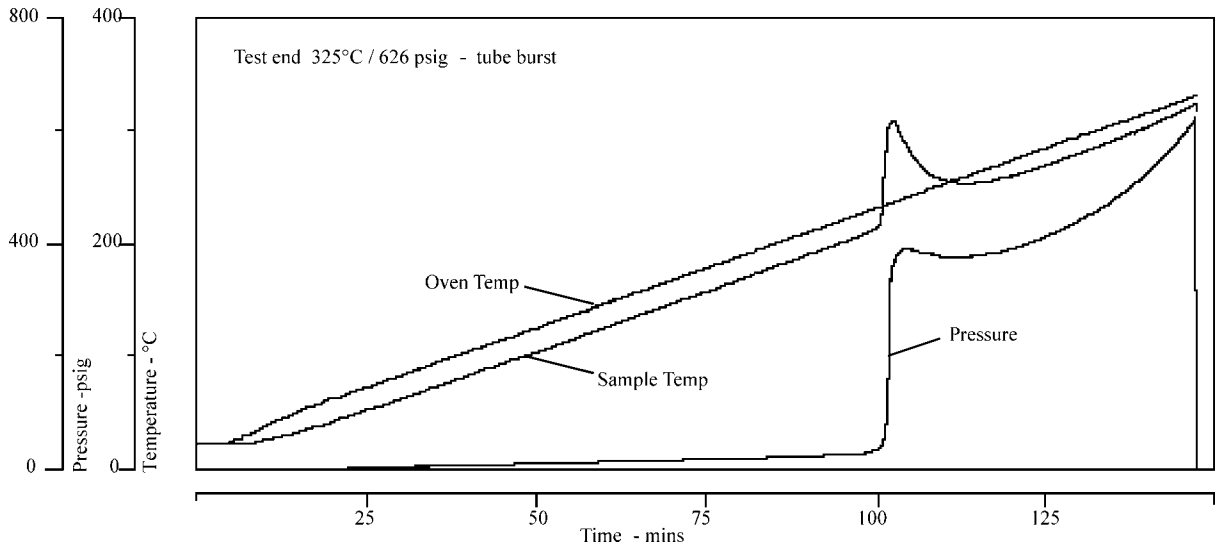

Figure 1. Typical Carius tube test thermogram

where the baseline is unclear/difficult to interpret. Clearly though, comparative tests with other thermal stability tests would be required in order to determine a safe allowance for scale up. Temperature measurement in standard microwave reactors is usually by external IR and a more accurate temperature measurement method, e.g. internal sheathed thermocouple would be required. Also, residual pressure measurement and an Antoine plot of the pressure/temperature data could yield approximate gas evolution data as in the Carius tube test.

A larger scale or adiabatic microwave based thermal stability test would be significantly more challenging to develop.

REACTION HEAT

From a chemical hazards viewpoint batch reactors are the least desirable for any type of chemical reaction. Once initiated, usually by heating, exothermic all-in processes will run-away until reaction is complete and one needs to ensure that this does not lead to reactor over-pressurisation, as well as possible environmental considerations. For “normal” chemistry an adiabatic calorimeter is usually employed to determine the heat of reaction and adiabatic temperature rise but as indicated above it would be difficult to develop a similar test for microwave chemistry. However, this is probably academic as the microwave penetration depth (several centimetres for water at 2.45 GHz.), will limit the scale of an ‘all-in’ microwave reactor. Also, producing the required microwave power input would be increasingly difficult with increasing scale. For example, in a lab-scale microwave reactor a microwave power of ~ 300 W is normally applied to a 3–10 ml sample; to obtain a similar heating profile on a 5 litres scale would require a microwave heating source of the order of 300 kW.

Isothermal calorimetry can yield overall heat of reaction and chemical power output data for semi batch processes and this data can also be applied to continuous reactor systems. Provided that the same product is generated in the microwave reaction as via conventional heating the presence of a “microwave effect” would not affect the overall heat of reaction (Hess’s Law), although the power output profile could be different. When assessing such a process one could analyse the reaction product from the microwave process and compare with that from a normal isothermal calorimeter reaction and if they are very similar then one can be confident that the calorimetric data will be valid. If one ensures that the reaction is carried out at a temperature at which reaction rate is rapid/instantaneous then the heat of reaction data can be used to generate power output data which can be used to determine reactor cooling requirements. Kinetic data from isothermal calorimetry can be used to determine this reaction temperature. High-pressure reactors are available for calorimetric studies where the required reactor temperature exceeds the boiling point of the batch.

GAS EVOLUTION

Gas evolution data would be generated along with heat data in an isothermal calorimeter for reactions at ambient pressure. Gas generation at elevated pressures would be more

difficult. This may require frequent venting at a relief pressure to estimate gas evolution rates during which heat would be lost and so affect the power output measurement — but this could be allowed for. However, under conditions where reaction rate is rapid and gas evolution is associated with the normal reaction exotherm, then the rate of gassing could be calculated. For microwave reactions under pressure one would need to consider how gas would be safely disengaged, including the potential for 2-phase, hybrid flow, etc.

SUPER-HEATING/THERMAL RUNAWAY

Super-heating can, and has been, the source of incidents of ‘exploding’ reaction tubes in laboratory scale reactors. Many microwave absorbing solvents can achieve temperatures well in excess of their boiling point during microwave irradiation³ (Table 2), which can result in sudden, rapid and significant increase in vapour pressure.

As indicated previously the loss tangent is a measure of how well a substance absorbs microwave energy. The relaxation time, τ , is defined as the time it takes one molecule to return to 36.8% (1/e) of its original state when the electric field is switched off. The relaxation time is temperature dependent and decreases with increasing temperature. For microwave frequency of 2.45 GHz, if an organic solvent has a relaxation time >65 ps, then the loss tangent will increase with temperature and the majority of solvents fall within this category¹. Under microwave irradiation, as the temperature increases the solvent converts more microwave energy into thermal heat energy which increases the rate of temperature rise and self-heating occurs which can lead to thermal runaway. For example water and methanol have a relaxation time <65 ps (Table 1) and would not be expected to lead to thermal runaway with continued irradiation but ethanol and higher alcohols, which have τ values >65 ps would. Although this is not a chemical reaction hazard per se, appropriate choice of solvent, reactor configuration and reaction conditions

Table 2. Boiling points (°C) for various solvents under normal and microwave conditions

Solvent	Normal conditions	MW conditions	Difference
Water	100	104	4
Dimethylformamide	153	170	17
Acetonitrile	81	107	26
Methanol	65	84	19
Ethanol	79	103	24
Acetone	56	81	25
Dichloromethane	40	55	15
Tetrahydrofuran	66	81	15
Ethyl acetate	78	95	17
Propan-2-ol	82	100	18

are important to avoid over-pressurisation as a result of solvent super-heating/thermal runaway. For a continuous reactor a knowledge of the heat generated by microwave absorbance at the reaction temperature is necessary (along with the reaction power output) to determine the reactor cooling requirements.

MICROWAVE EFFECT

Although increases in reaction rates and selectivity are widely reported using microwave calorimetry there is some debate as to whether or not a specific (non-thermal) “microwave effect” exists, i.e. that application of microwaves in some way change the nature of the chemistry going on. One argument against this is that the energies involved are not sufficient to break chemical bonds. Tables 3 and 4 show that the energy associated with microwave radiation is an order of magnitude lower than that of Brownian motion.

Another is that the observed increased rates of reaction and in selectivity can be explained otherwise e.g., by localised transient superheating. As microwaves are absorbed by chemicals at different rates one can imagine several scenarios, which could affect heating characteristics.

If the solvent and reactants all exhibit similar microwave absorption characteristics then the whole reaction mixture will heat up at a uniform rate (assuming good agitation) and at equilibrium there will be a uniform temperature throughout the bulk. Heating characteristics would therefore be no different to conventional heating under the same heating rate and final bulk temperature conditions. Clearly though the rapid heating rates achievable with microwaves could affect the selectivity/rate of formation of by-products.

In a system in which the solvent absorbs microwaves and the reactants do not then the reactants temperature will be raised by heat conduction from the bulk solvent and will therefore never exceed the bulk solvent temperature. Again, one would not expect any significant reaction rate differences compared with conventional heating other than that from the rate of increase in the batch temperature.

If the solvent does not absorb microwaves or does so at a significantly lower rate than the reactants then the potential exists for significantly higher localised reactant temperatures than measured in the bulk solvent. The temperature differences will be

Table 3. Comparison of microwave energy with that of other radiation

Radiation	Frequency(MHz)	Energy(eV)
Visible	$\sim 10^8$	2.5
Infrared	$\sim 10^6$	0.012
Microwave	2450	0.0016
Radio	1	10^{-9}

Table 4. Comparison of chemical bond energies

Bond Type	Energy (eV)
Ionic	7.6
C–H	4.51
C–C	3.2
Hydrogen Bond	0.04 to 0.44
Brownian Motion	0.017 (@200 K)

proportional to the rate the irradiation is absorbed by the reactants and solvent and the rate at which heat is dissipated by conduction to the bulk solvent, but there is no practical way of measuring this temperature difference. This effect could explain the increased reaction rates and selectivity compared with similar (bulk) conditions using conventional heating.

The balance of opinion appears to be against a specific (non thermal) microwave effect. However, as it cannot be completely discounted one needs to bear in mind its possible existence when assessing the chemical reaction hazards and recommending a basis for

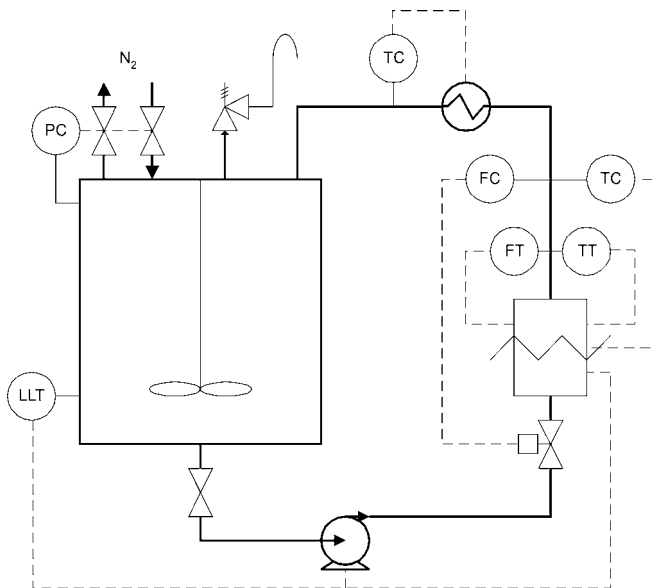
**Figure 2.** Flowsheet of a simple recycle reactor

safe operation; for example the development of a microwave thermal stability screening test as discussed earlier.

BASIS OF SAFETY

There are essentially three basis of safety strategies for avoidance/control of chemical reaction hazards,

- 1) **inherent safety** — no hazard even if a fault occurs
- 2) **preventative measures** — i.e. process control, including limiting reagent feed rate, high (or low) temperature trips, agitator/feed interlock trips etc.
- 3) **protective measures** — e.g., containment, venting, drown-out, etc.

Inherent safety is the preferred strategy but is usually difficult and/or cost prohibitive to fully achieve even for “normal” chemical processes. Failing this, process control is

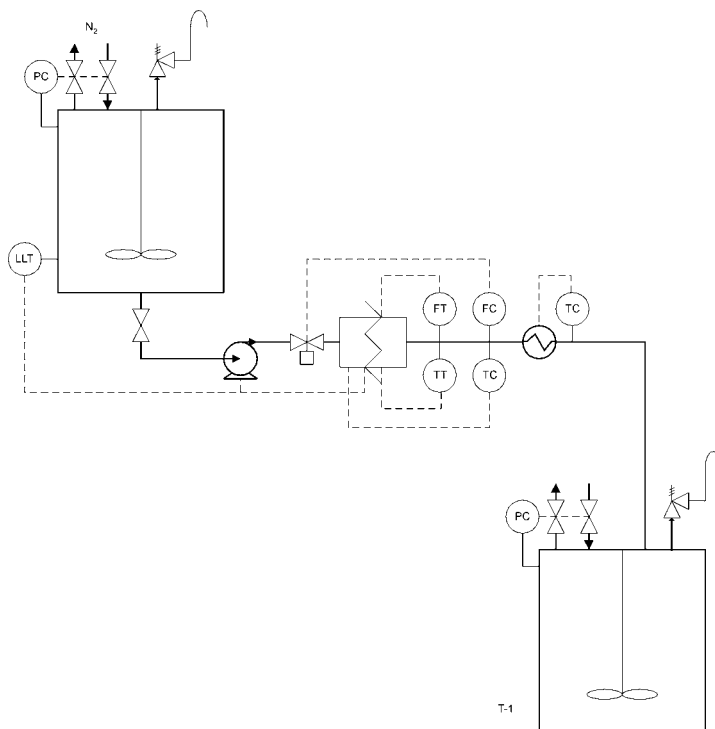

Figure 3. Flowsheet of a straight through continuous reactor

the preferred and most common basis of safety used within AstraZeneca. However, our strategy is to make chemical processes as inherently safe as possible.

To fully assess the chemical reaction hazards of a chemical process one needs a detailed process description as often the hazards are related to the way a process is operated rather than being intrinsically unsafe. However, it is possible to give a number of guidelines towards the development of a more inherently safe process, be that by conventional or microwave heating. With respect to scale-up of microwave reactors considerations to achieve this include:

Avoid all-in reactions — as discussed previously for microwave chemistry this mode of reaction will in any case be increasingly more difficult to operate as scale increases.

Use of continuous reactors — a continuous process is inherently safer than a batch or semi-batch process primarily due to the low inventory and usually shorter residence time at elevated temperature. Several continuous reactor designs are possible around open and closed loop systems (Figures 2–4⁴). A single pass system is more inherently safe than a closed loop system as recirculation of reagents and products are more likely

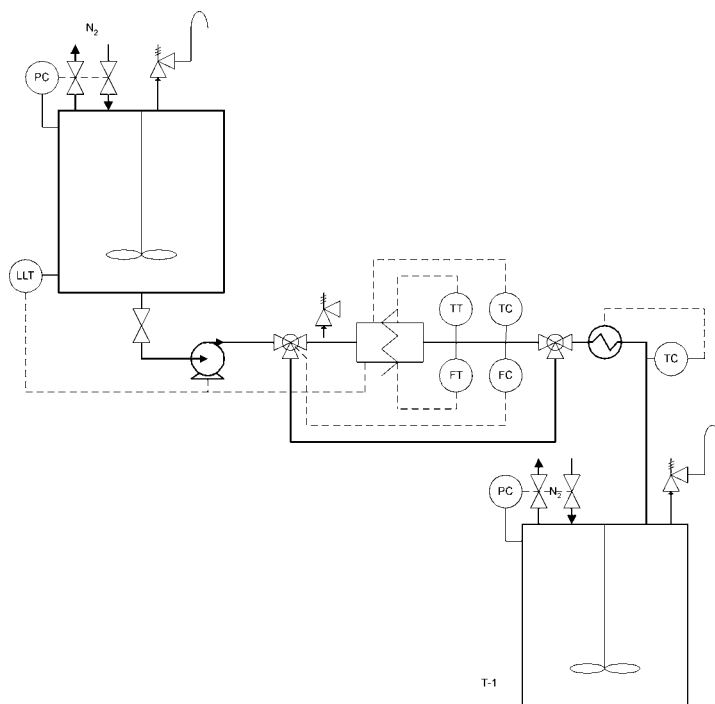

Figure 4. Flowsheet of a continuous reactor with recycle loop

to produce more thermally unstable intermediate reaction mixtures. Obtaining a representative sample for thermal stability testing would also be more difficult for a re-circulated closed loop system as the batch composition will be continually changing. Using a single pass continuous loop reactor the low inventory and short residence time would permit a smaller scale allowance for thermal stability data. However, one would still need to assess the thermal stability of the collected bulk product, for example external cooling of the receiver may be necessary.

Rapid reaction rate — to avoid accumulation and reduce residence time the reaction should be carried out at a temperature at which reaction rate is rapid. This may require elevated pressures but this could be minimised by use of a high boiling solvent system.

Efficient agitation — this is important to avoid localised overheating/superheating and accumulation of reagents. In a continuous flow system this could be achieved by ensuring turbulent flow within the reaction chamber.

Solvent choice — as indicated previously some solvents have a greater tendency to superheat. Higher boiling solvents with higher microwave absorbance, e.g. 1-methyl-2-pyrrolidinone (NMP) and dimethyl acetamide (DMA), are favoured as they are less prone to superheating and allow access to higher reaction temperatures at lower pressures. For less favourable solvents, such as tetrahydrofuran (THF) and toluene, superheating can be avoided by the addition of a small amount of a polar solvent. Solvents that decompose on heating, e.g. dimethylsulphoxide (DMSO), formic acid, and oxidising agents should be avoided. Care would also be required using solvents with relatively low auto-ignition temperatures e.g. 1,4-dioxane ($T_{AIT} = 180^{\circ}\text{C}$).

Limited scale-up — this is employed as a safe working strategy during development of “normal” chemical processes and this should equally be employed for a new technology such as microwave assisted chemistry. This would mean the requirement for intermediate sized reactor systems which, for continuous flow reactors, may not be as straightforward as scale-up of batch or semi-batch type reactors.

REFERENCES

1. Gabriel, C; Gabriel, S; Grant, E.H; Halstead, B.S.J; Mingos, D.M.; Chemical Society Reviews, 1998, volume 27.
2. Lidström, P; Tierney, J; Wathey, B; Westman, J; Tetrahedron Report Number 589, Tetrahedron 57 (001) 9225–9283.
3. Baghurst, D.R; Mingos, D.M.P; J. Chem. Soc. Commun., 674–677 (1992).
4. Reactor flowsheets (Figs 2–4) reproduced by permission of P Howarth, AstraZeneca.